

www.ascender.com.tw



*A Specialized Manufacturer of Deep Hole Drilling Machine*

深孔加工機械專業製造廠



鋒鑽機械股份有限公司  
ASCENDER MACHINERY INC.

台灣42942台中市神岡區國豐路一段163號  
ADD: No.163, Sec. 1, Guofeng Rd., Shengang  
Dist., Taichung City 42942, Taiwan

TEL: 886-4-2528 3785

FAX: 886-4-2528 3727

E-mail: dhm.ascend@msa.hinet.net

http://www.ascender.com.tw

07.2013 / 1000 05-226/S Sunway 04-2322 7907

鋒鑽機械股份有限公司

深孔加工機械專業製造廠

A Specialized Manufacturer of Deep Hole  
Drilling Machine



CNC 深孔加工機  
CNC Deep Hole Drilling Machine

ASCENDER MACHINERY INC.



# TG series CNC Deep Hole Drilling Machine

## CNC 深孔加工機

- 高效率三軸定位槍鑽深孔加工機
- 適合於偏心孔加工之應用
- 模具、平板、塊狀工件適用
- High efficiency three-axis positioning gun drilling machine.
- Suitable for eccentric hole machining.
- Applicable for molds, platens and blocks machining.

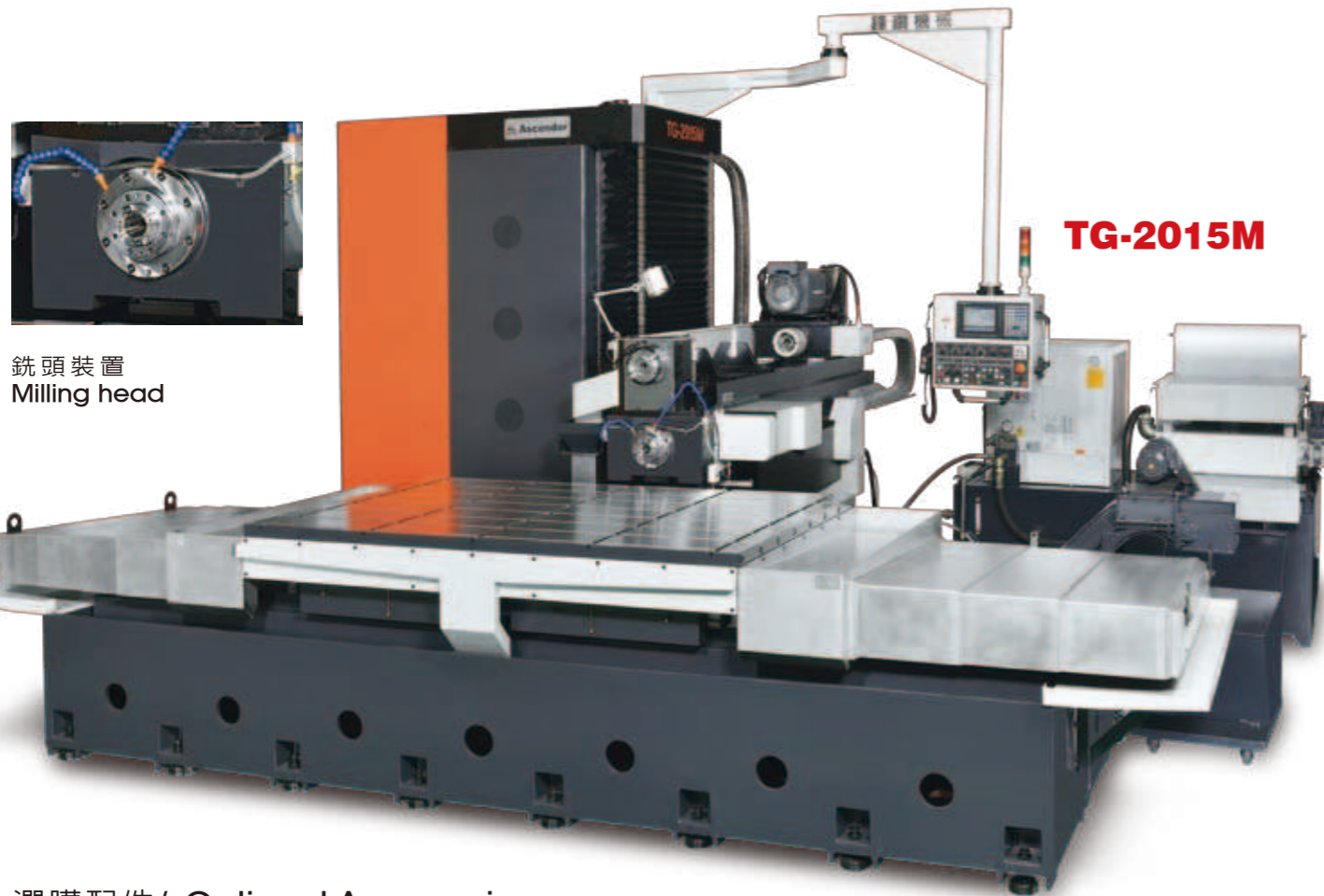

銑頭裝置  
Milling head

### 選購配件/ Optional Accessories :

銑頭 MILLING HEAD			W軸進給 W-AXIS FEED		
主軸錐度 Spindle Taper	BT-40		W軸馬達 W-axis Motor	AC servo 3.5kw	
主軸馬達 Spindle Motor	11kw				



TG 槍鑽系列 - 三軸位移孔加工  
TG Gun Drilling Series-Three Axes Feed Machining

TG-2010



### SPECIFICATION

Model	TG-1000	TG-1500	TG-2010	TG-2015	TG-2510	TG-2515		
加工孔徑 Drilling dia.	ø3~30 mm (opt. ø4~40 mm)							
加工深度 Drilling depth.	1,000 mm		1,500 mm (opt. 2,000 mm)					
工作台面積 Working table size (mm)	1,200x1,000	1,700x1,000	2,200x1,500		2,700x1,500			
工作台承載能力 Table loading capacity	8,000 kg		15,000 kg					
T形槽溝 T-shape slot	18 x 6 x 160 mm		22 x 8 x 180 mm					
X 軸行程 X - axis travel	1,000 mm	1,500 mm	2,000 mm		2,500 mm			
Y 軸行程 Y - axis travel	800 mm		1,000 mm	1,500 mm	1,000 mm	1,500 mm		
Z 軸行程 Z - axis travel	1,650 mm		2,200 mm (opt. 2,800 mm)					
控制器 Controller	MITSUBISHI / FANUC							
主軸轉速 Spindle speed	10~8,000 rpm							
主軸馬達 Spindle motor	7.5 kW							
X/Y/Z 軸馬達 X / Y / Z - axis motor	4.5 / 3.5 / 2 kW		7 / 4.5 / 2 kW					
快速進給 Rapid traverse rate	X, Y - axis 6,000 mm/min , Z-axis 10,000 mm/min							
切削油箱容量 Coolant tank capacity	1400 L							
高壓切削液馬達 Hi-pressure coolant pump	7.5 HP							
低壓切削液馬達 Low-pressure coolant pump	10 HP							
切削油冷卻機 Cooler capacity	7,500~9,000 kcl/hr							
鼓式紙帶過濾機 Drum type paper filter	200 L/min							
機械重量 New weight	12,000 kgs	14,000 kgs	20,000 kgs	23,000 kgs	25,000 kgs	28,000 kgs		
佔地面積	長	L	5,000	5,500	6,500	6,500	7,000	7,000
	寬	W	4,000	4,000	5,500	5,500	5,500	5,500
	高	H	2,950	2,950	3,300	3,800	3,300	3,800

- 本公司對產品規格、設計均不斷研究改進，上述規格若有變更，恕不另行通知。
- Design and specification are subject to change without prior notice.

# GC series CNC Deep Hole Drilling Machine CNC 深孔加工機

- 高效率單軸、雙軸、多軸式槍鑽深孔加工機
  - 適合於中心孔加工之應用
  - 適用於模具配件、車輛零件、液壓元件...等各式圓棒類工件加工
  - 另可依客戶工件需求加工條件訂製機械規格
- High efficiency single spindle, double spindles and multiple spindles gun drilling machine.
  - Suitable for center hole machining.
  - Suitable for various cylindrical parts machining, such as mold accessories, automotive parts and hydraulic parts, etc.
  - Custom machine specifications are available to meet specific machining requirements.

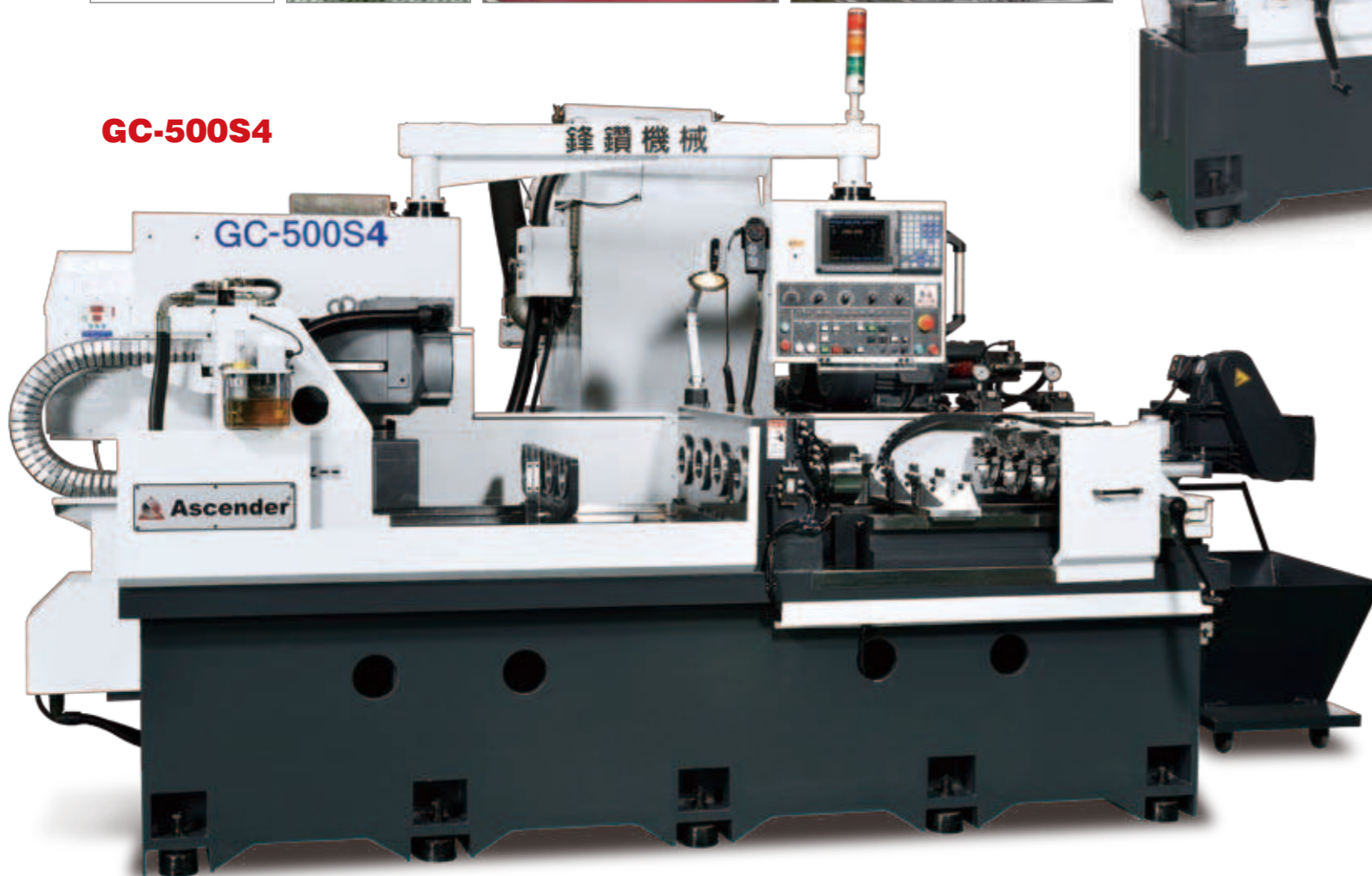
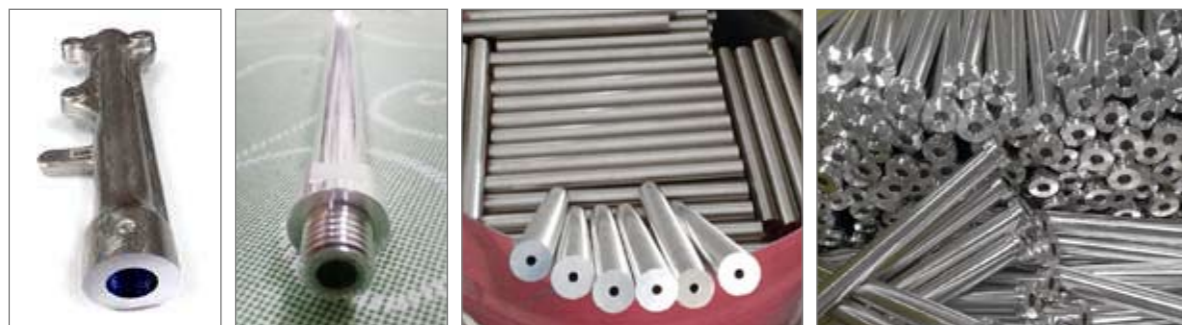

GC - 500 S4 D

D: 雙轉 D: Double rotation

S: 單軸 S2: 雙軸 S4: 四軸  
S: Single spindle S2: Double spindles S4: Four spindles

加工深度: 500/1000/1500/2000 mm  
Machining depth: 500/1000/1500/2000 mm

GC 槍鑽系列 - 中心孔加工  
GC Gun Drilling Series - Center Hole Machining



## SPECIFICATION

Model	GC-500S4	GC-1000S2	GC-1000S2D	GC-1500S2	GC-1500S2D	GC-2000S	GC-2000SD
加工孔徑 Drilling dia.	ø3~25 mm	ø3~30 mm (Opt. ø4~40 mm)					
加工深度 Drilling depth	500 mm	1,000 mm	1,500 mm		2,000 mm		
Z 軸行程 Z-axis travel	1,200 mm	1,600 mm	2,200 mm		2,800 mm		
控制系統 Controller	Fanuc / Mitsubishi						
主軸轉速 Spindle speed	10~8,000 rpm						
主軸馬達 Spindle motor	7.5 kw						
Z 軸馬達 Z-axis motor	3.5 kw					2.0 kw	
切削油冷卻機 Cooler capacity	12,500~15,000 kcl/hr					7,500~9,000 kcl/hr	
鼓式紙帶過濾機 Drum type paper filter	360 l/min					200 l/min	

- 本公司對產品規格、設計均不斷研究改進，上述規格若有變更，恕不另行通知。
- Design and specification are subject to change without prior notice.

## Optional Accessories 選購配件:



中心架導套  
STEADY REST GUIDE BUSH

SPECIFICATION:

- $\phi 3 \sim 7.9$  mm with bearing 6202
- $\phi 8 \sim 17.5$  mm with bearing 6205
- $\phi 17.6 \sim 26.5$  mm with bearing 6207
- $\phi 26.6 \sim 40$  mm with bearing 6209



前支撐導套  
FRONT GUIDE BUSH

SPECIFICATION:

- $\phi 3 \sim 5$  mm with bearing 628
- $\phi 5.1 \sim 7.9$  mm with bearing 6202
- $\phi 8 \sim 17.5$  mm with bearing 6205
- $\phi 17.6 \sim 26.5$  mm with bearing 6207
- $\phi 26.6 \sim 40$  mm with bearing 6209



刀導套  
GUIDE BUSH

SPECIFICATION:

- $\phi 3 \sim 30$  mm
- $\phi 31 \sim 40$  mm

## Gun Drilling Tool Type 鎗鑽刀具型式:

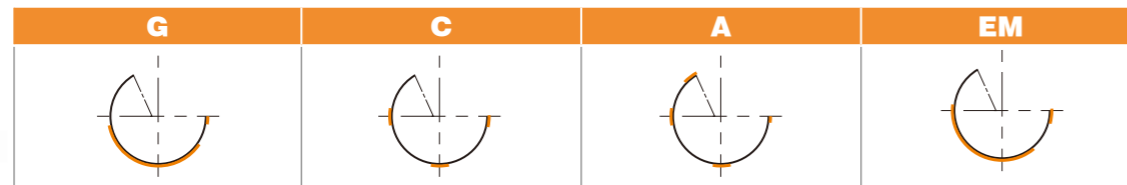

- G**
- 適用於所有材料
  - Suitable for all materials

- C**
- 不鏽鋼材料
  - 難加工材料
  - Stainless steel
  - Hard-to-cut materials

- A**
- 鋁
  - 高尺寸精度場合
  - Aluminum
  - High accuracy required

- EM**
- 鋼、鑄鐵、及軟材料
  - Steel, cast iron and soft materials

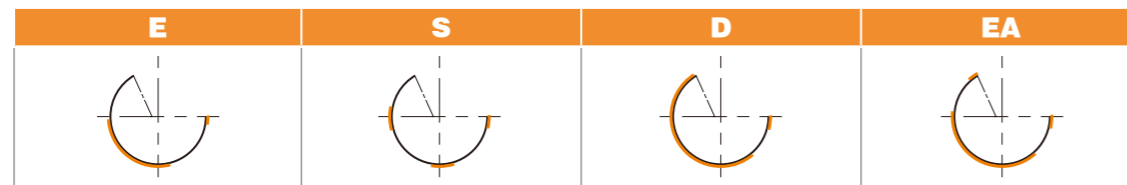

- E**
- 所有材料和塑料
  - 推薦用於高速鑽
  - All materials and plastics
  - Recommended for high speed drilling

- S**
- 鋼
  - 高精度場合
  - 完好的表面質量
  - 適合加工短孔
  - Steel
  - High accuracy required
  - Good surface finish
  - Short hole

- D**
- 鑄鐵及球墨鑄鐵
  - 鑄件零件高精度孔場合
  - Cast iron and ductile iron
  - High accuracy hole machining for cast iron parts

- EA**
- 交叉孔加工- 鋼和鋁
  - 從斜面鑽入及鑽出
  - Cross-hole machining for steel and aluminum
  - Bevel surface drilling in and out.

## Drilling Tool Grinder

### 槍鑽磨刀頭



- 底座為選購附件
- Stand is an optional equipment



Unit: 60 Hz

鑽頭研磨尺寸	Grinding drill size	$\phi 2 \sim 32$ mm $\phi 6 \sim 45$ mm
電機功率	Motor	0.25 kw
砂輪尺寸	Grinding wheel size	$\phi 125$ mm(5")
砂輪轉速	Grinding wheel speed	3450 rpm
重量	Weight	160 kg
外形尺寸	Machine dimensions	720 x 610 x 880 mm

## De-Oiling Machine

### 脫油機

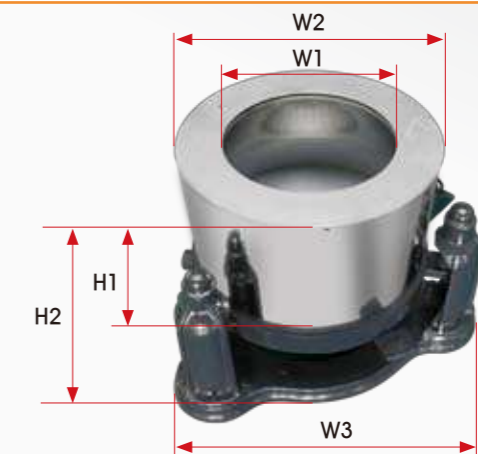

Model		HP-20	HP-22
寬度 Width	W1	$\phi 410$ mm	$\phi 450$ mm
	W3	$\phi 1100$ mm	$\phi 1170$ mm
馬力 Motor	HP	1 HP	2 HP
	R.P.M	1,000	1,000
容量 Capacity	L	23 L	28 L
皮帶 Belt		A52	A54