



www.balancesystems.com

 Systems

 Machines

 Service

 Monitoring

磨削製程優化 x CNC和機外量測的協同應用 Products & Application Overview

v.03.230127

**Your trusted partner
for balancing and grinding quality**

Process control and monitoring systems for machine tools and
balancing machines for rotating components for over 50 years

USync
心得科技工業股份有限公司

主講人: 巫岳勳 經理

何謂研磨？

研磨是一種將固體物質化為較小顆粒的操作。

在研磨作用下，機械力克服了固體物質內部的鍵合力。被研磨物質的尺寸、形狀皆會改變。

研磨也是一種精加工方法。通過砂輪與工件在一定壓力下的相對運動，對加工表面進行的精整加工，以達到更高的光潔度。



各式各樣的研磨機床類型

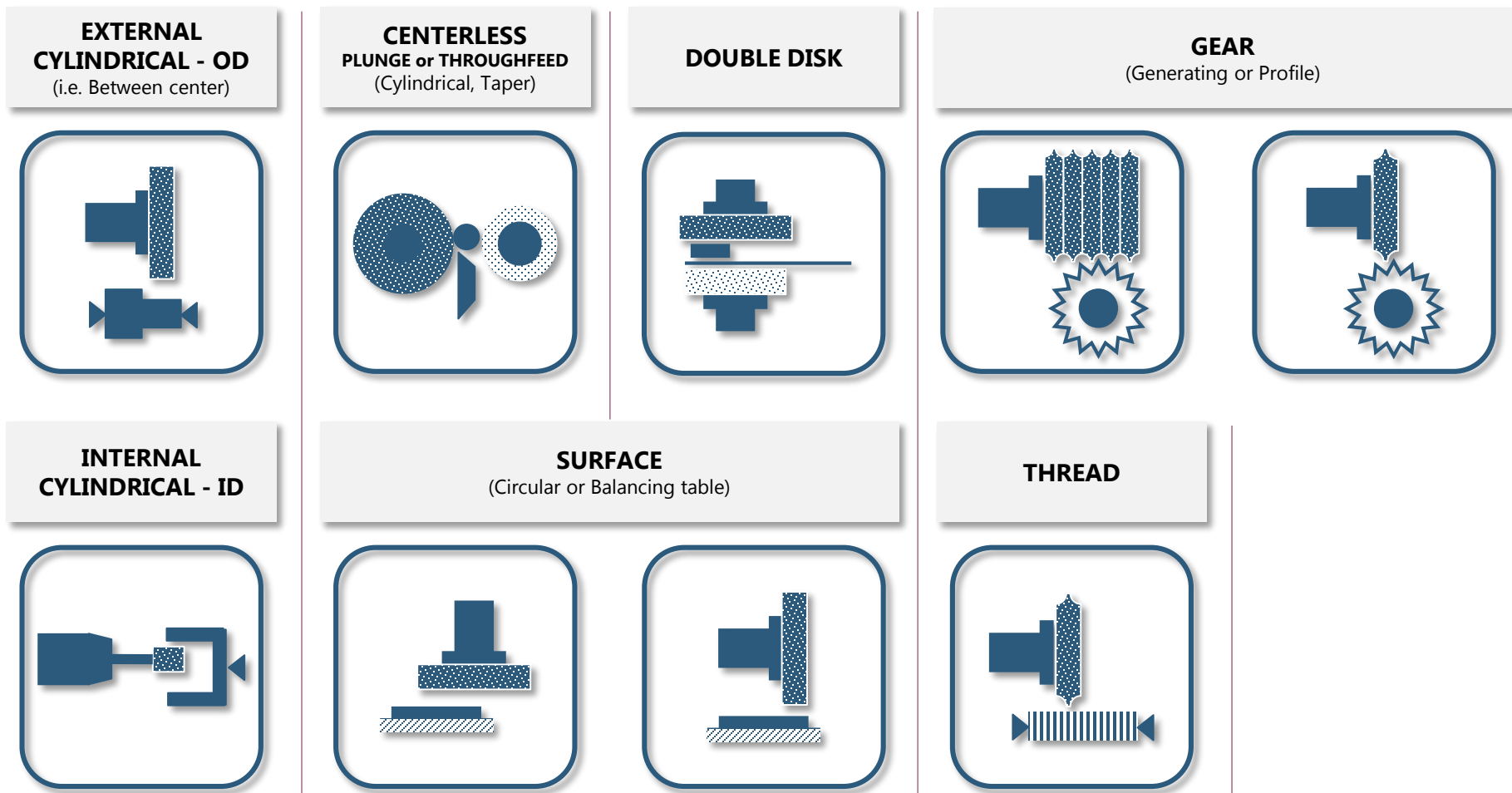

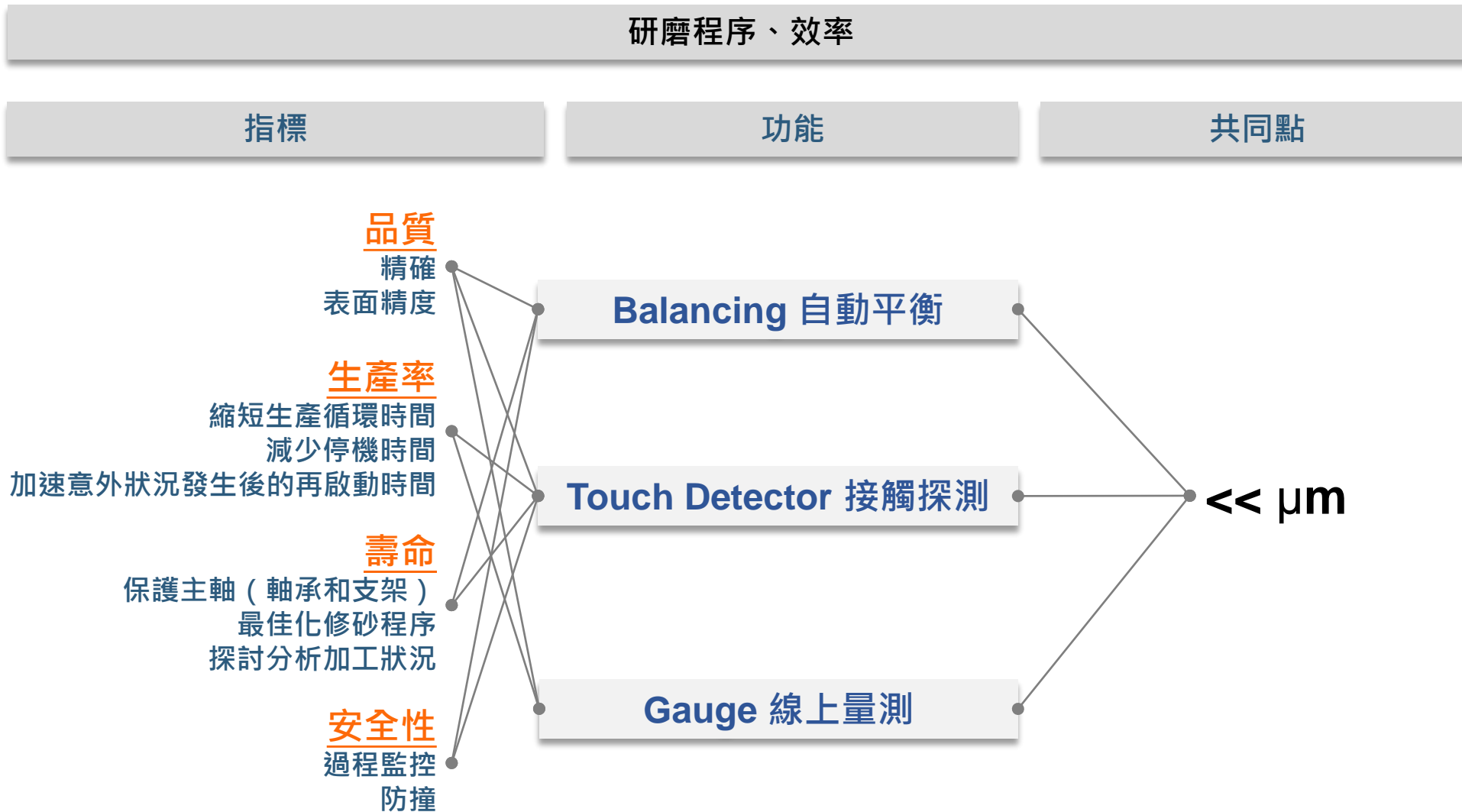

VM25 模組化之磨床線上多功能 系統

BALANCER

- 1 & 2 Plane Automatic Balancing
- Neutral cycle
- 1 & 2 Plane Manual Pre-Balancing
- Rotation Speed Monitor
- Frequency Analysis
- AE sensor for Gap&Crash
- Wireless technology

Control unit

- Digital I/O
- Profibus DP
- Profinet RT I/O
- Control Panel HMI
- PC Windows HMI
- Remote control
- Service package

TOUCH DETECTOR

- Touch grinding control
- Dressing process control
- Anti-crash monitor
- Touch probe function
- Based on AE & Power sensor

GAUGE

- Pre/In/Post-Process gauging
- Flagging
- Roundness & shape analysis
- Interrupted surfaces
- Wide range up to 25.4mm
- Anti-crash system
- Absolute gauge solutions



Why grinding line equipment ?

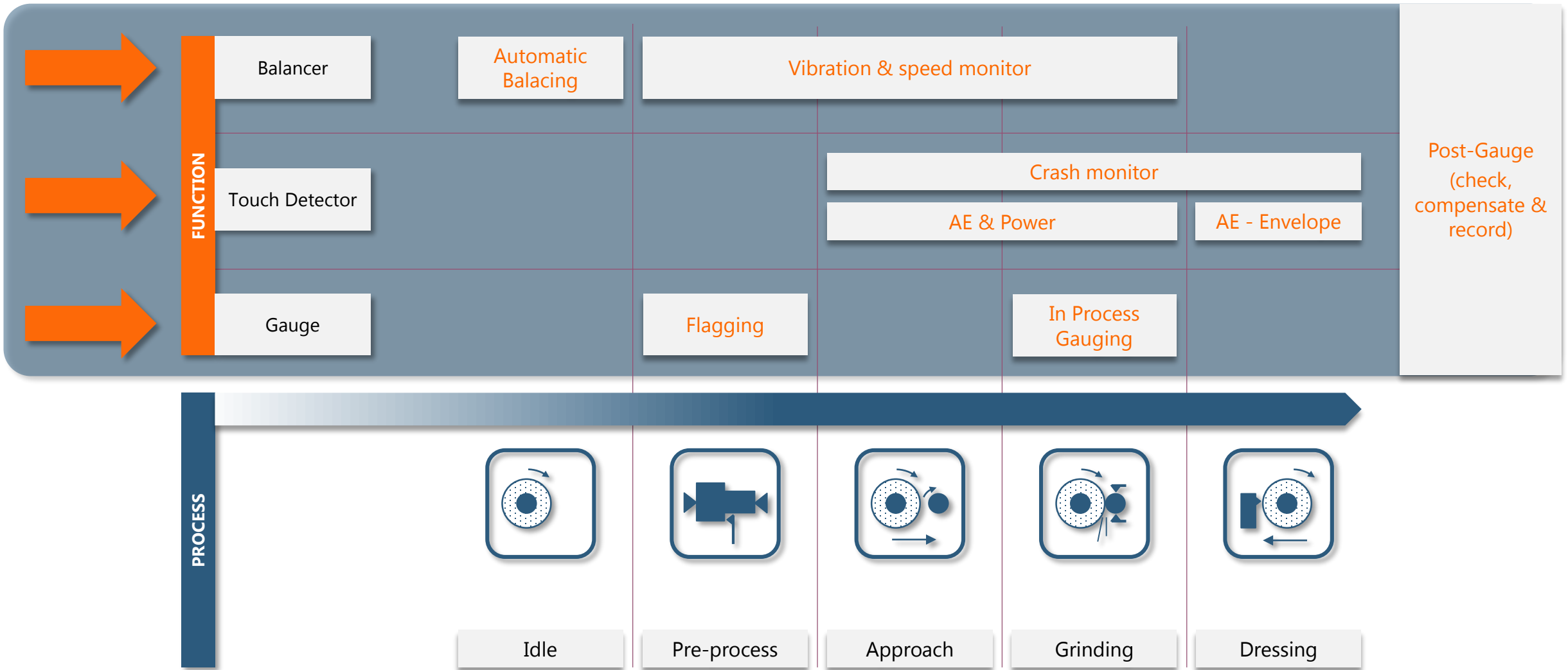

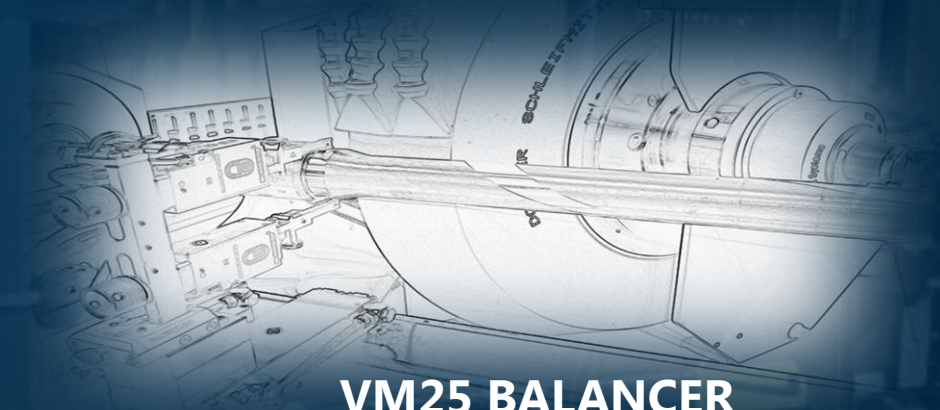
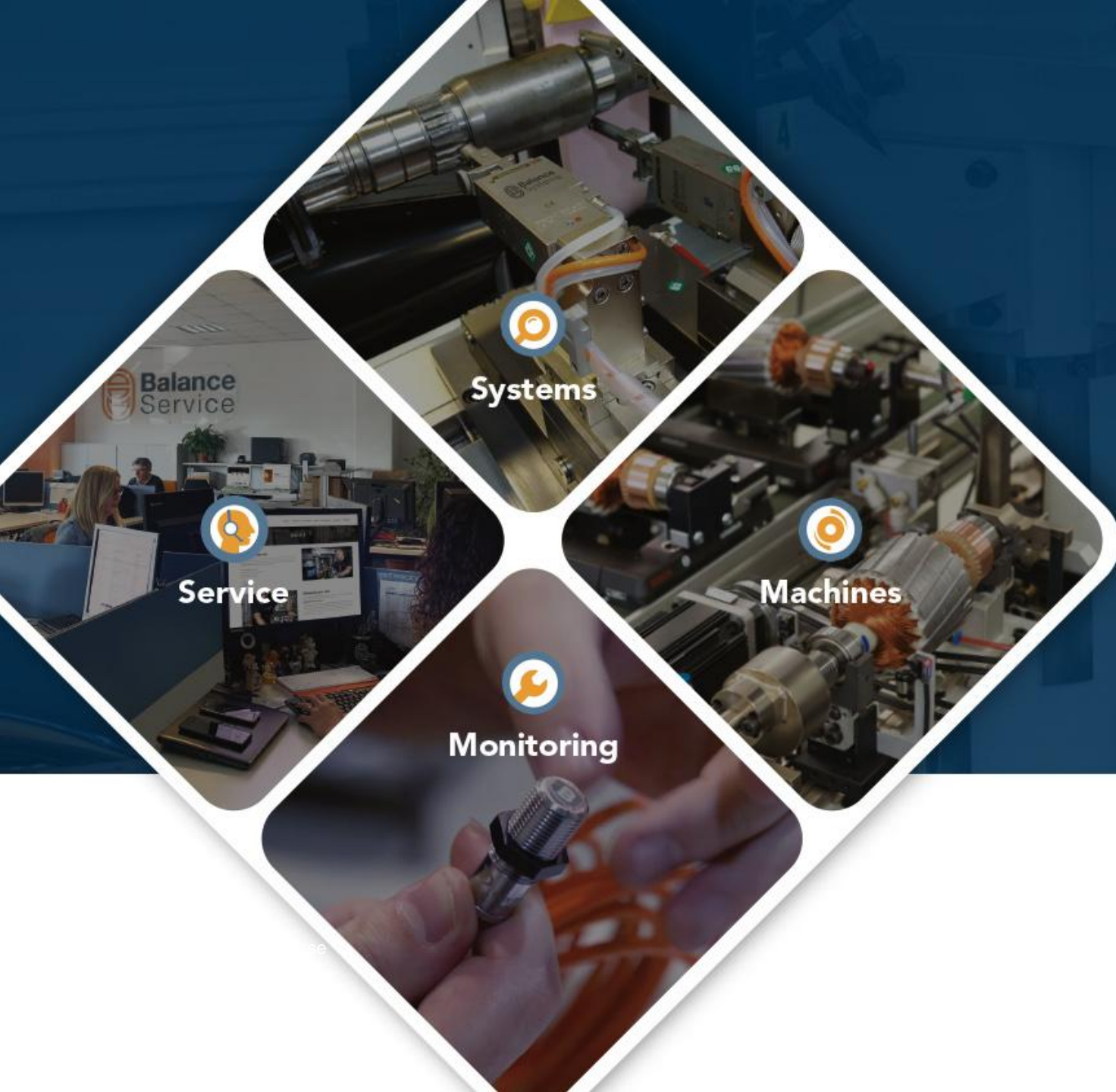

VM25 BALANCER
線上砂輪自動平衡
v.08.230228

**Your trusted partner
for balancing and grinding quality**

Process control and monitoring systems for machine tools and balancing machines for rotating components for over 50 years

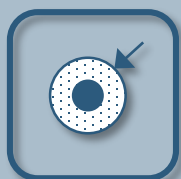

Automatic Balancing

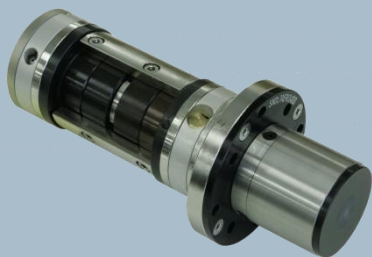
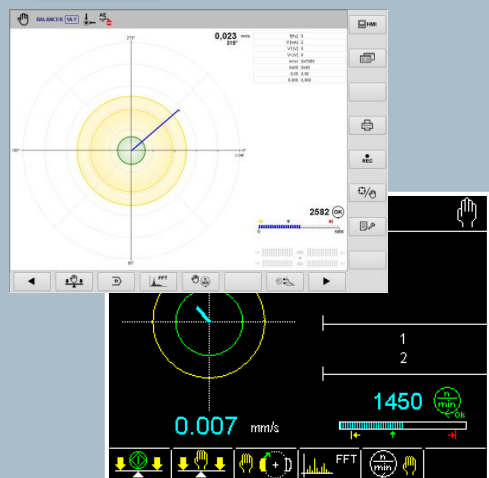

有經驗的磨床操作員都知道，砂輪不平衡對工件表面質量將帶來負面影響。

- ❑ 在車削過程中，特別是在高速運轉下，主軸上會因不平衡產生不良振動，從而導致工件加工不規則。
- ❑ 此外，還會出現幾何缺陷（刮痕刻面），並使機床負載過重：主軸軸承、滑軌和滾珠軸承直接受到這種振動的不當負荷，使用壽命縮短。



即使砂輪預先平衡過，但，這只是一次性的操作，其效果很快就會喪失。

事實上，在所有可能的不平衡原因中（例如：幾何不規則性、同心度誤差等），其中最重要的是砂輪材料的密度不均勻。

- ▶ 因此，砂輪的磨損和修整週期會改變不平衡的相位和幅度，繼續產生振動。
- ▶ 只有對砂輪進行機器內、線上的即時監測和平衡，才能顯著提高磨削過程的質量和穩定性。

What is the unbalance ?

From **ISO 1925**: "...condition which exists in a rotor when vibration force or motion is imparted to its bearings as a results of centrifugal forces"

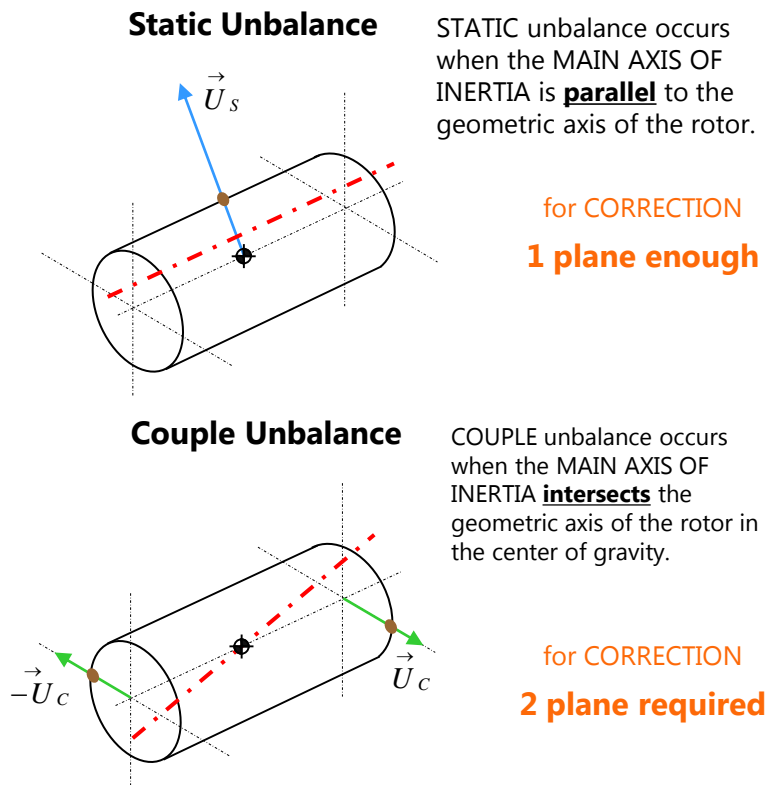

$$\vec{U} = m \cdot \vec{r}$$

- \vec{U} unbalance vector, units [gmm]
- m unbalance mass, units [g]
- \vec{r} radius vector, distance of the center of gravity of the unbalance mass from the shaft axis, units [mm]

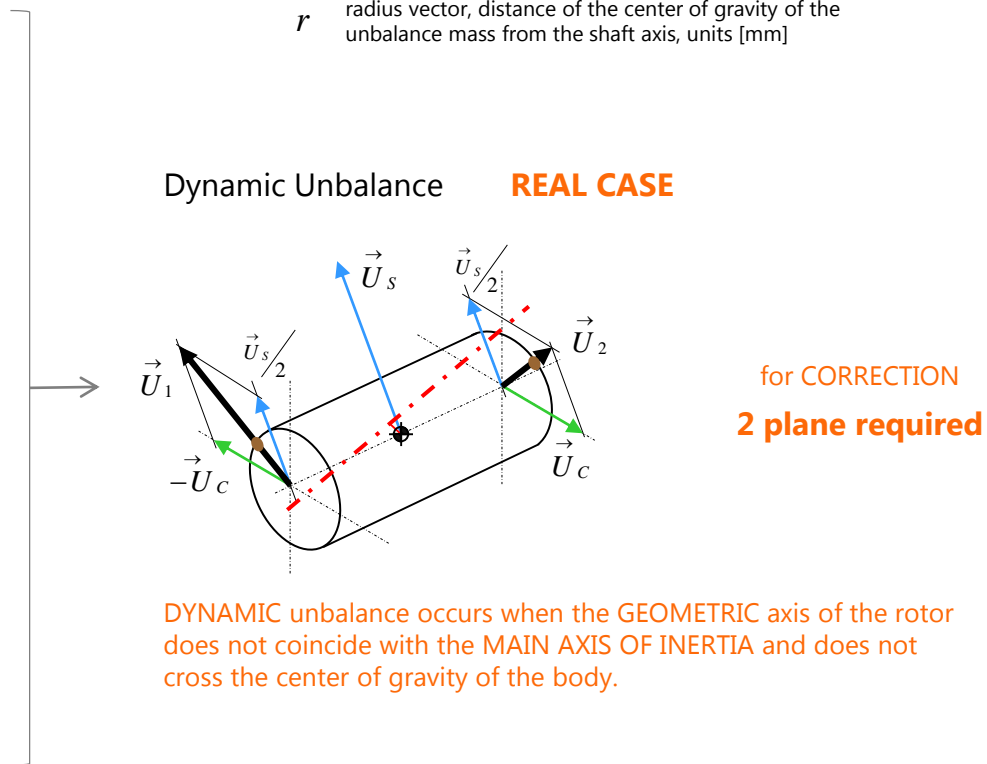

Form **ISO 1925**: "... is a **procedure** by which the mass distribution of a rotor is checked and, if necessary, adjusted in order to ensure that the vibration of the journals and/or forces on the bearings at a frequency corresponding to the service speed are within specified limits"

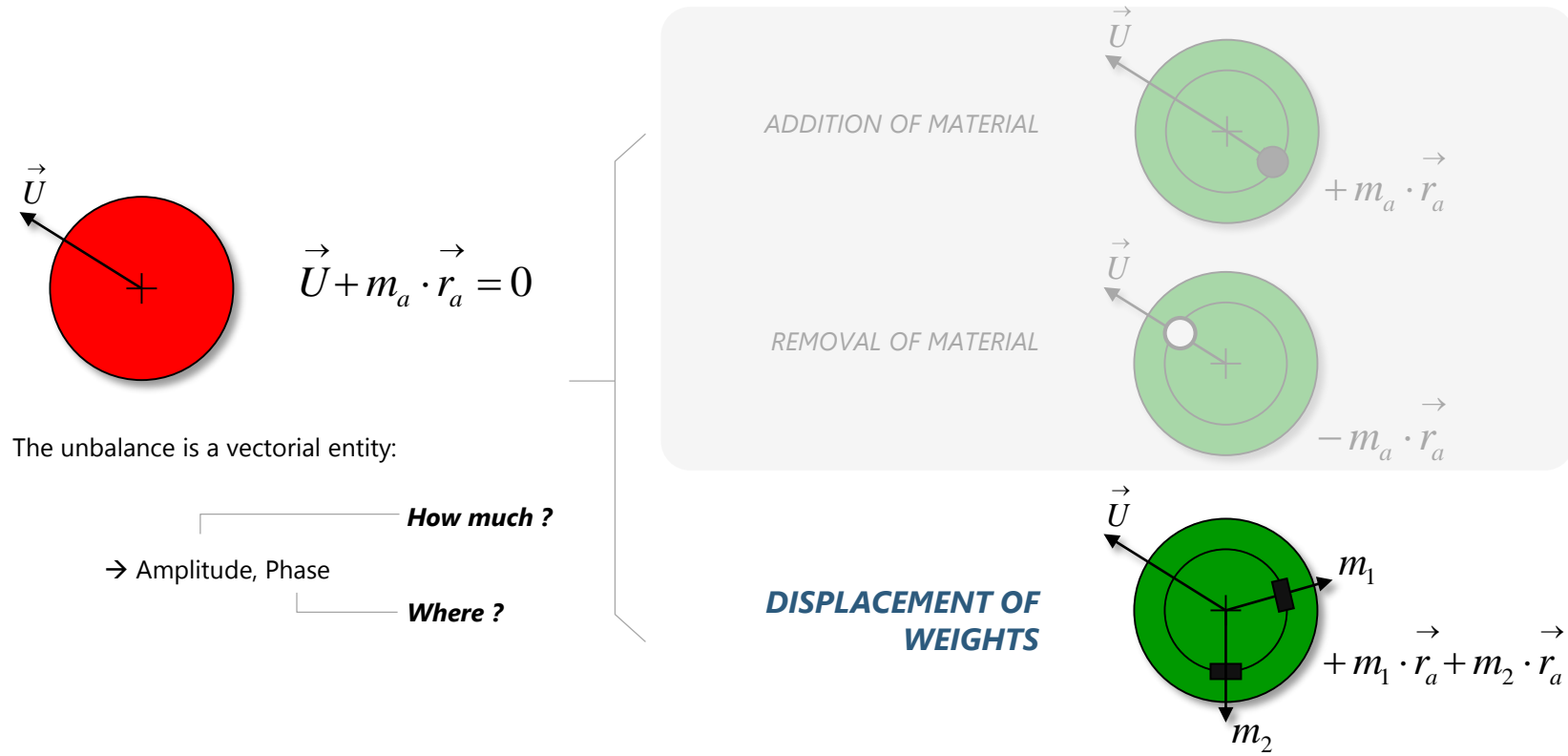

VM25 模組化之磨床線上多功能 系統

BALANCER

- 1 & 2 Plane Automatic Balancing
- Neutral cycle
- 1 & 2 Plane Manual Pre-Balancing
- Rotation Speed Monitor
- Frequency Analysis
- AE sensor for Gap&Crash
- Wireless technology

Control unit

- Digital I/O
- Profibus DP
- Profinet RT I/O
- Control Panel HMI
- PC Windows HMI
- Remote control
- Service package

TOUCH DETECTOR

- Touch grinding control
- Dressing process control
- Anti-crash monitor
- Touch probe function
- Based on AE & Power sensor

GAUGE

- Pre/In/Post-Process gauging
- Flagging
- Roundness & shape analysis
- Interrupted surfaces
- Wide range up to 25.4mm
- Anti-crash system
- Absolute gauge solutions



原因：砂輪幾何形狀的缺陷

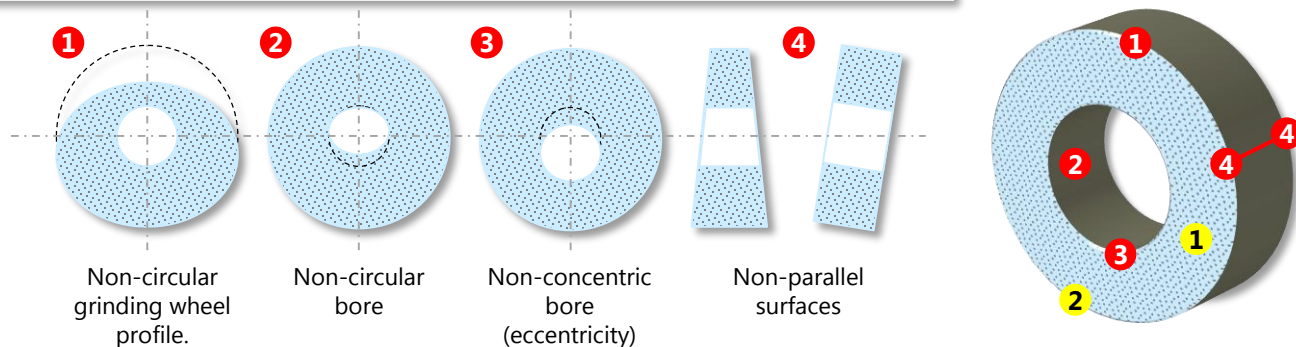

原因：材質結構不均勻

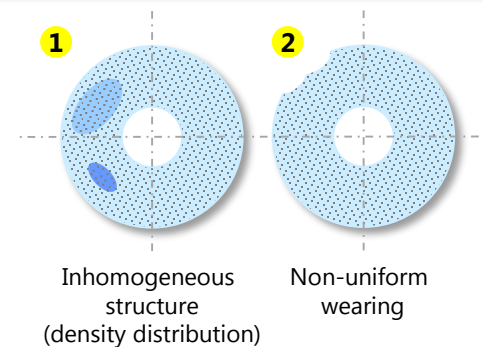

原因：組件或裝配錯誤

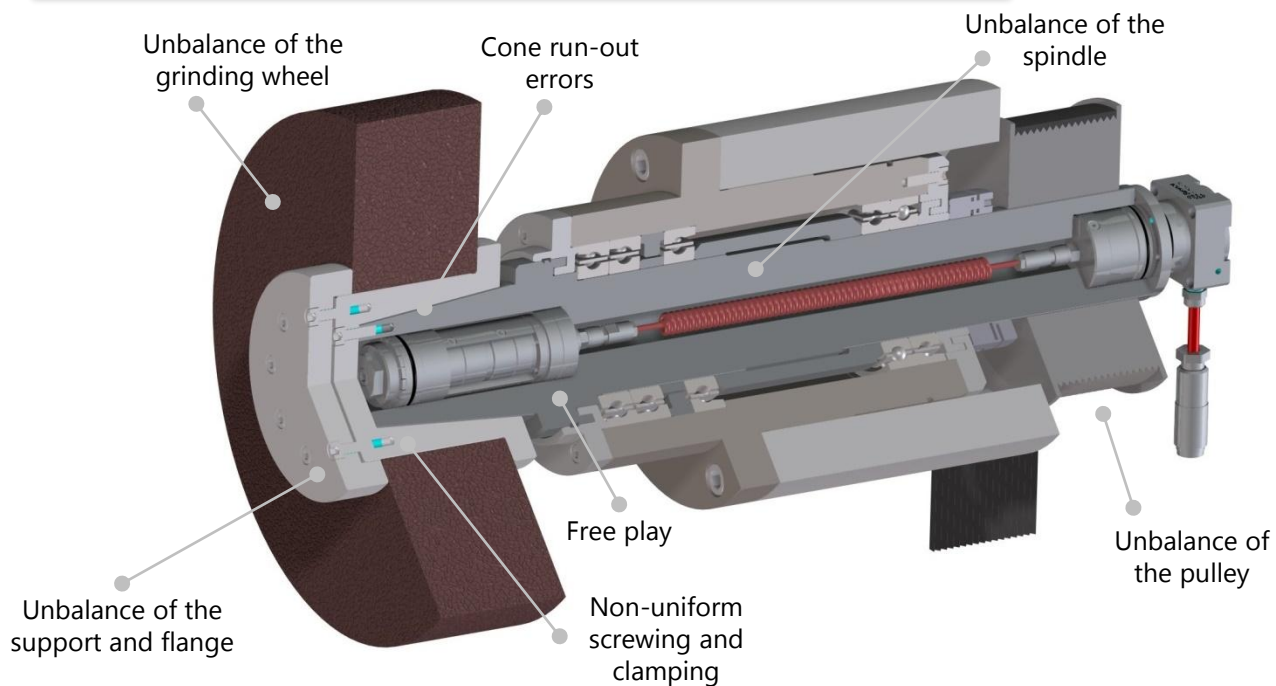

不平衡的影響

... is a VIBRATION

- 它反映了主軸軸承的支撐
- 它強調主軸軸承縮短了它們的壽命
- 它會導致表面不平整
- 它擾亂了其他相鄰的設備

WATCH NOW



手動平衡步驟



自動平衡步驟

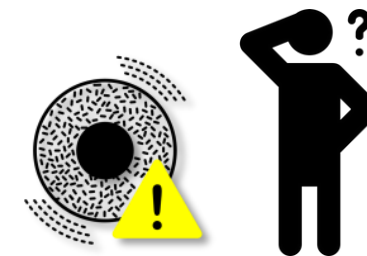

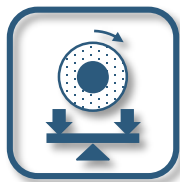

1 Plane NoLink (contact less)

1 Plane Brushes

Conventional

High performance



Conventional

Built-in spindle
Front side collector

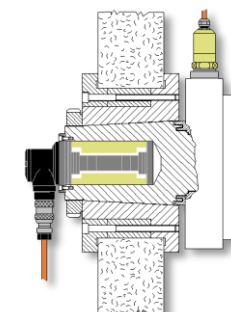
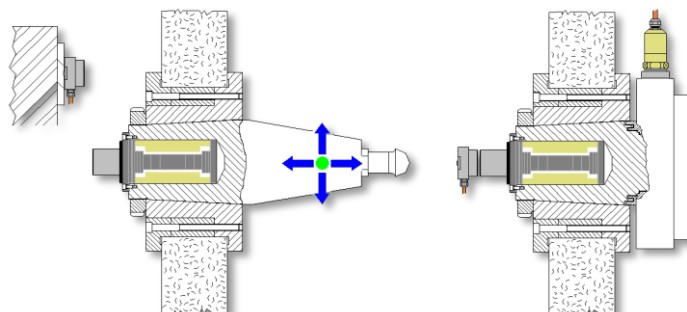

Built-in spindle (self-lock or flange)
Back side collector

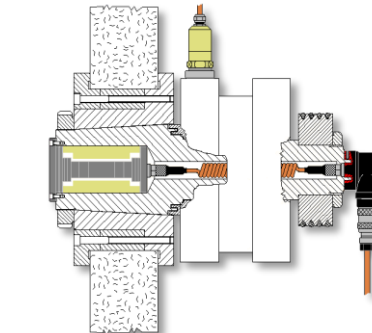
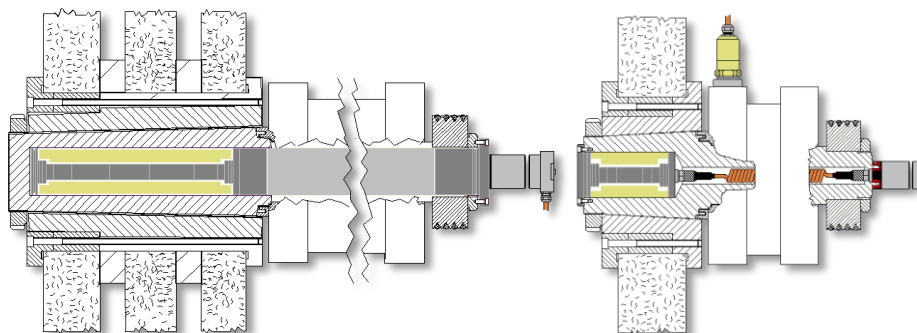

External flange mounting (for retrofitting)
Front side collector

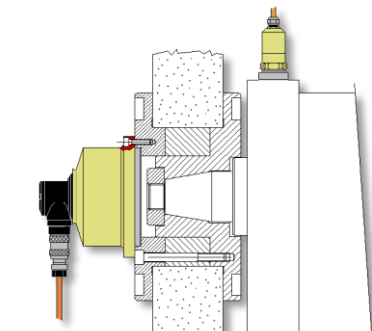
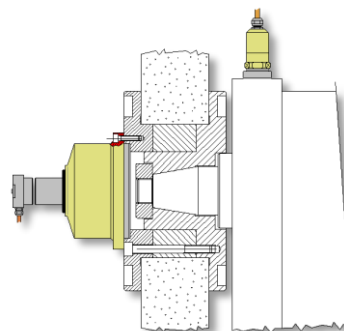
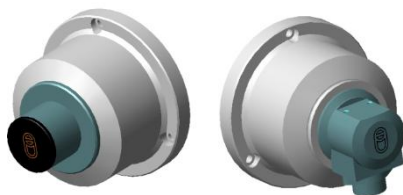

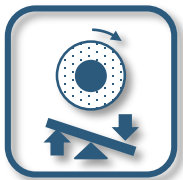

ABSOLUTE[®]
Balancer

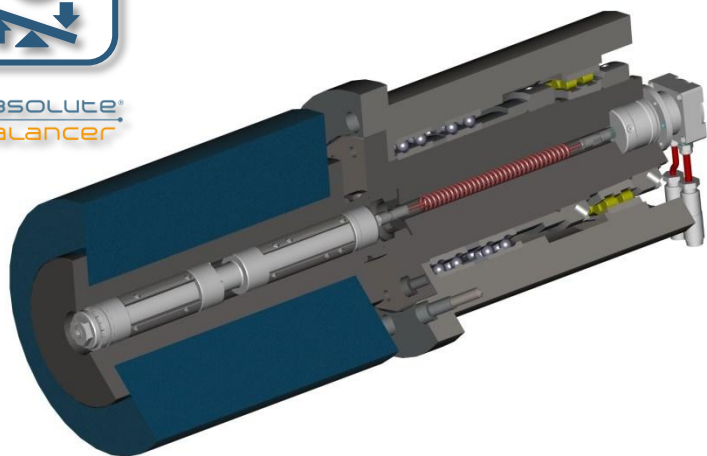

1st option

- Upgrade from 1 to 2 plane
- Dynamic unbalance correction
- Built-in spindle
- 1 side AXIAL collector

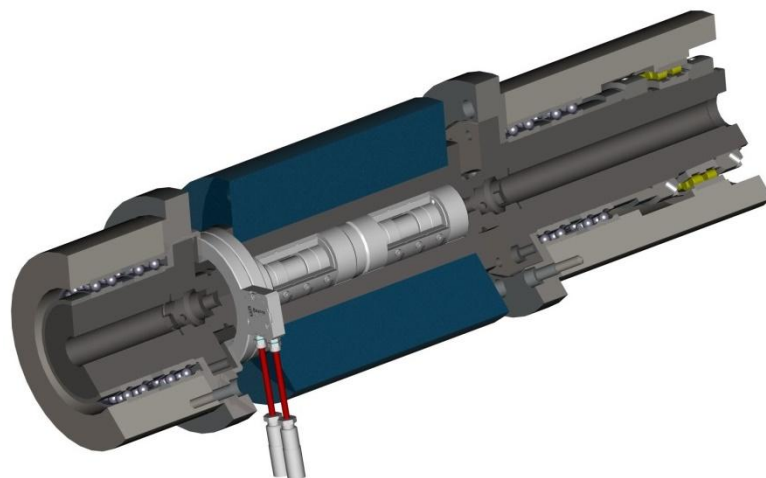

2nd option

- Dynamic unbalance correction
- Built-in spindle with adjustable compensation capacity
- 1 side RING collector

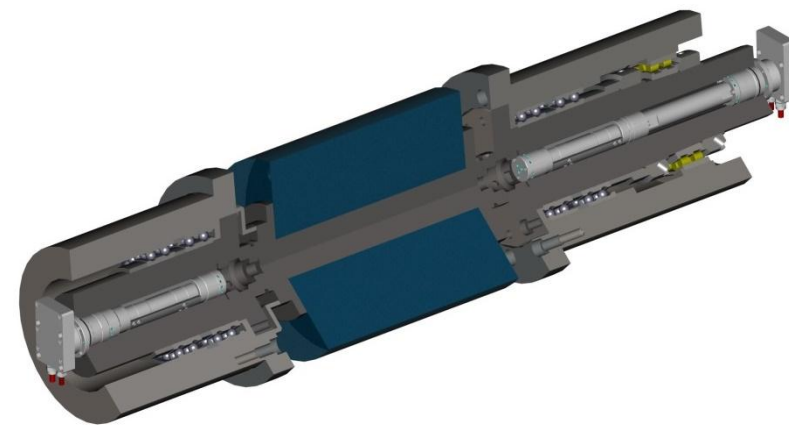

3rd option

- Spindle up to 20.000 rpm
- Dynamic unbalance correction
- Built-in spindle (main bearing and counter bearing)
- 2 sides collector

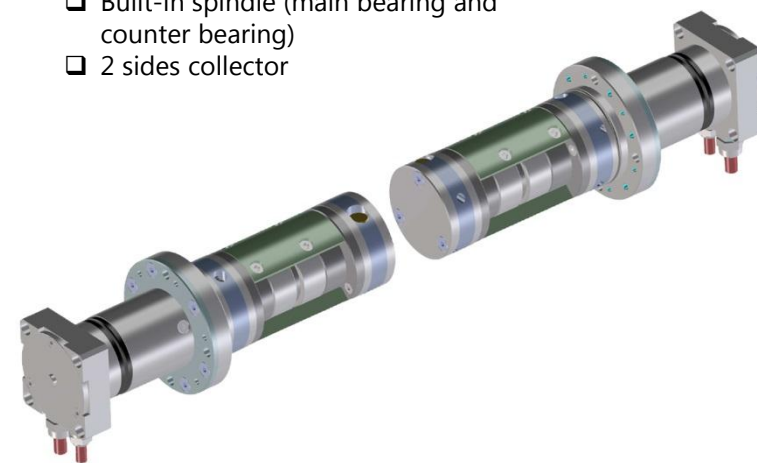

Competitors...

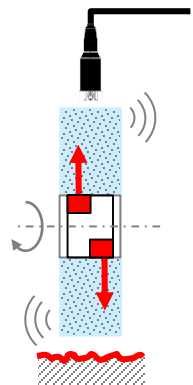
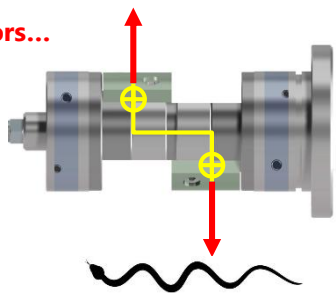

相同的
不平衡值
不同的品質與結果

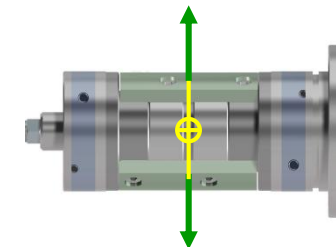
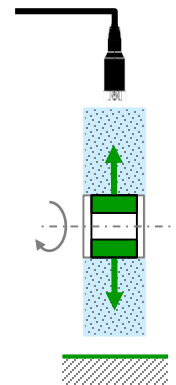

TECHNOLOGY

缺陷的表面

不正确的接合 (i.e. 齒輪)
不平衡
表面波紋
頻繁修整



優質的表面精度

高轉速(利於研磨)
不造成表面波紋
更長的修砂間格



QUALITY

不對稱設計

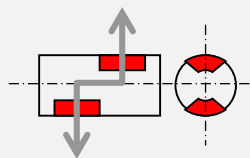

- 本身 力矩造成影響
 - 當平衡塊位於相對 180°
 - 由於殘留的動態不平衡力矩
- 扭力
 - 最糟的狀況
 - 造成表面波紋產生

COAXIAL DESIGN

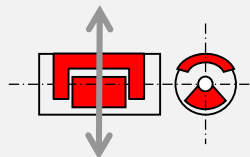

- 零力矩平衡具以下限制:
- 沒有高精度平衡能力
- 中立位置(平衡塊相對 180°) → 只能作為選項提供, 且精度不高
- 相同平衡機尺寸的補償能力較弱 → 應用範圍受限。

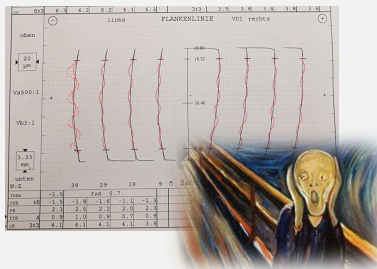

UNIQUE SYMMETRIC DESIGN

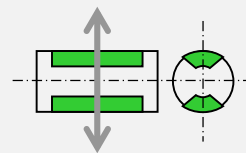

- 零力矩平衡 → 不增加扭矩
- 中立位置(平衡塊相對 180°) → 中性效應 → 可以放心、安全地更換砂輪
- 不增加殘餘不平衡 → 表面處理完美
- 在相同尺寸條件下, 提供最高補償能力
- 高平衡精度

CASE OF GEAR GRINDING

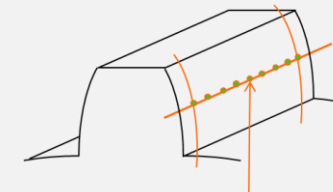
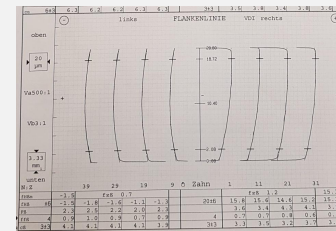

Perfect SHAPE OF THE FLANK

GEAR MANUFACTURE IN PRESENCE OF UNBALANCE

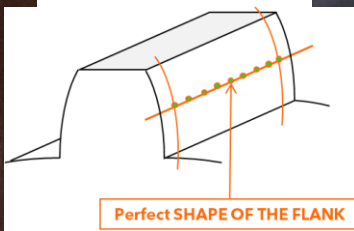

GEAR MANUFACTURE AIDED BY BALANCE SYSTEMS' BALANCER

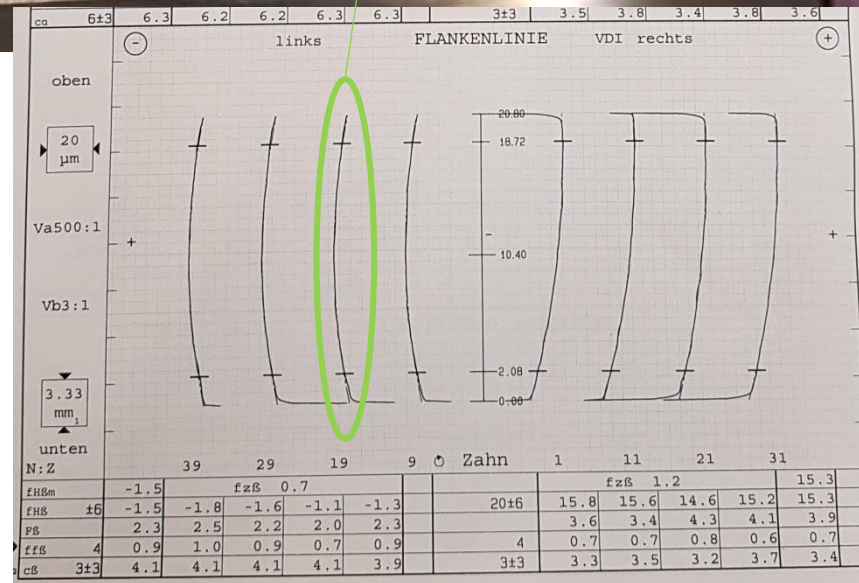
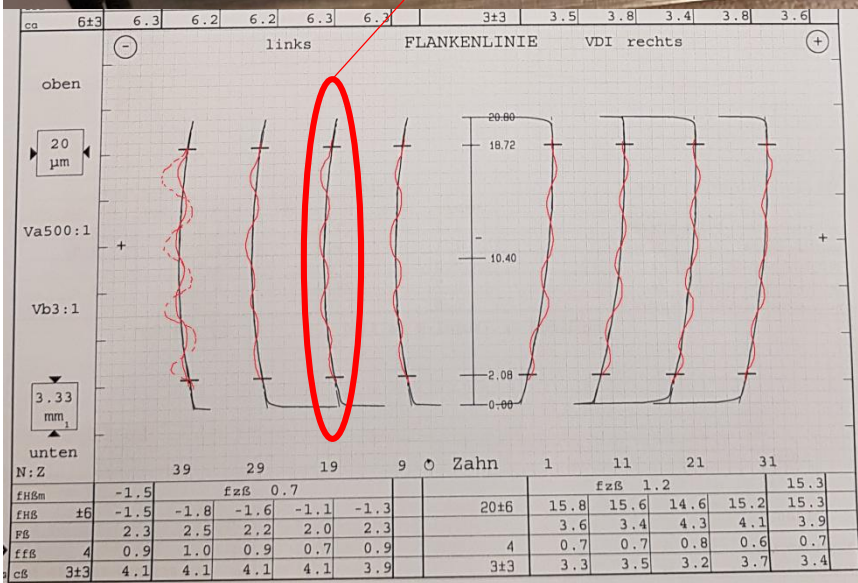
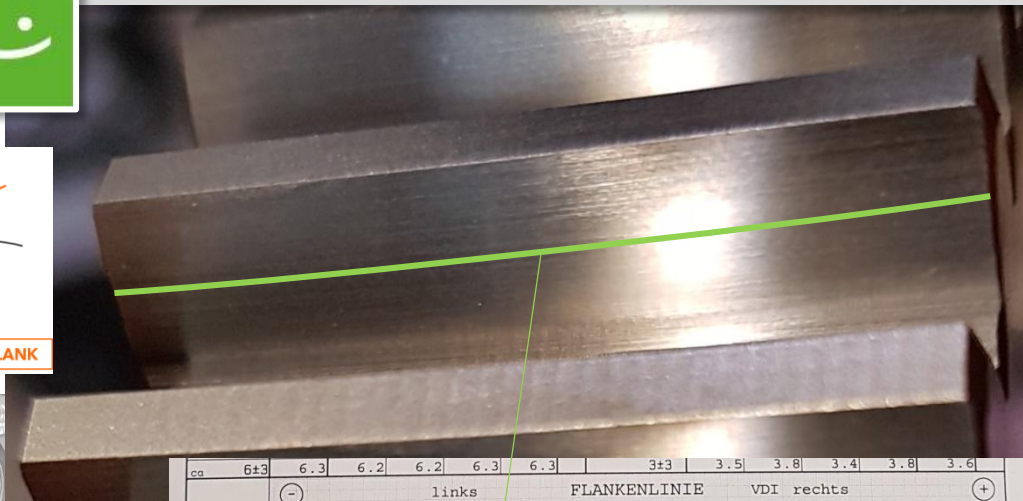
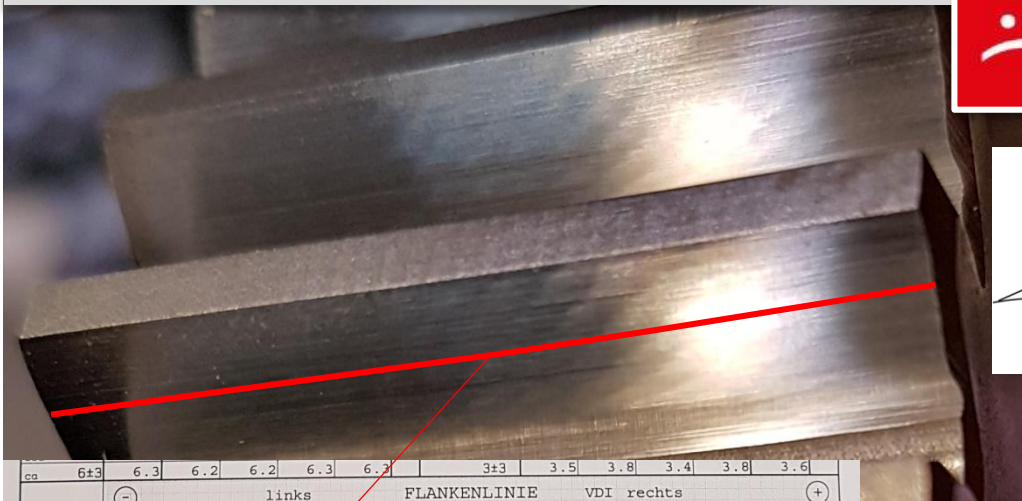

Built-in Conventional Balancer



- Historical basic product
- Suitable for any general purpose application
- Minimum Built-in diameter 42mm
- **Try & Error** balancing algorithm

Built-in HIGH Performance Balancer

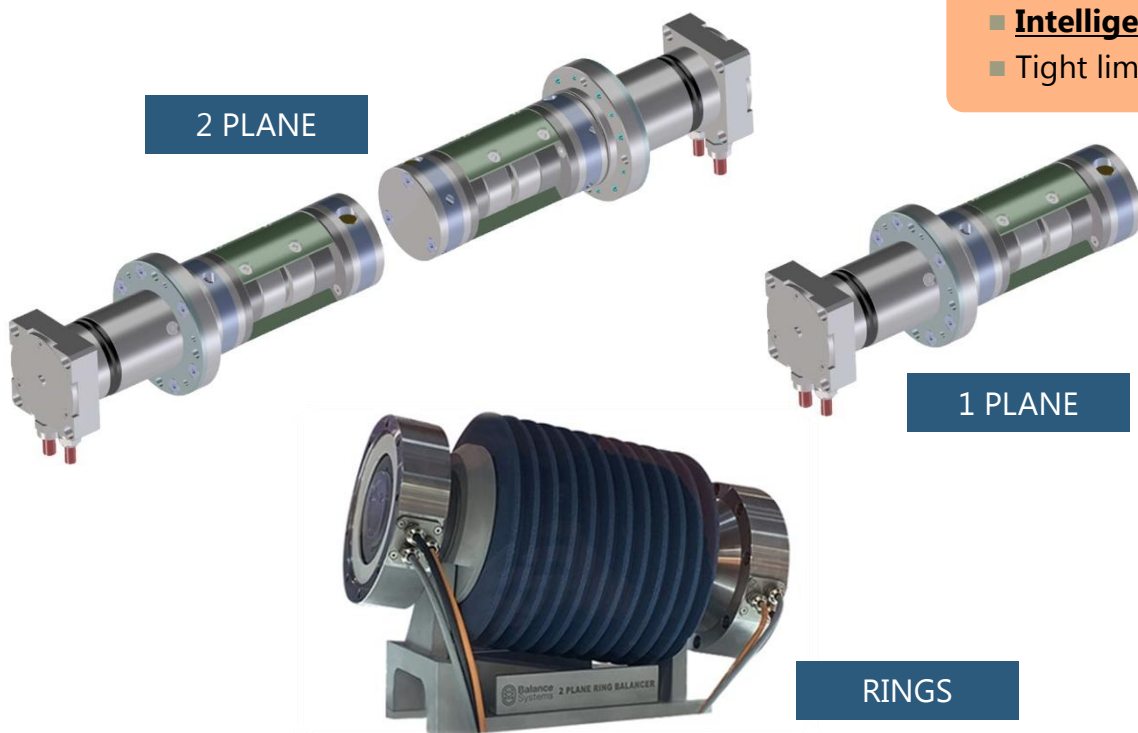
- Enhanced product for high precision grinding processes (i.e. gear, super-abrasive, high speed)
- Suitable for any general purpose application
- Minimum Built-in diameter 32mm
- **Intelligent Try & Error** balancing algorithm
- Tight limits achievable in short balancing time

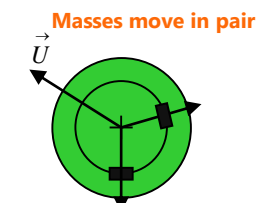
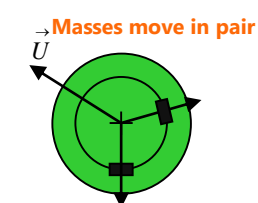

- **Status of the art in balancing technology**
- **Suitable for any 1 plane and 2 plane applications**
- **Built-in and Ring balancer models**
- **Minimum Built-in diameter 28mm**
- **Deterministic balancing algorithm based on Machine Learning**
- **Zero residual unbalance target, achievable in predictable balancing time**

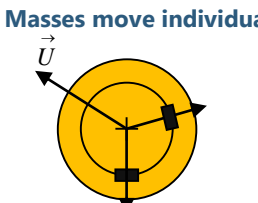
Balancer technology	1 plane balancing		2 plane balancing		Unbalance correction
	T_{min} [sec]	T_{max} [sec]	T_{min} [sec]	T_{max} [sec]	
CONVENTIONAL BALANCER Try & Error Algorithm Balancing precision: 20 - 30 $\mu\text{m/s}$	5	40	20	120	
HIGH PERFORMANCE BALANCER Intelligent Try & Error Algorithm Balancing precision: 5 - 15 $\mu\text{m/s}$	5	20	15	90	
 Deterministic Algorithm & Machine Learning Balancing precision: < 5 $\mu\text{m/s}$	2	8	3	20	

WATCH NOW



2 PLANE

The above table shows the achievable balancing precisions and balancing times for the different Balance Systems' balancer technology on 1 and 2 plane

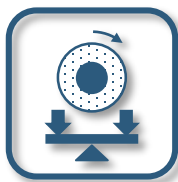

環形平衡 的特點

- ❑ 自動、快速和可靠的平衡系統，適用於沒有可用空間容納傳統內置平衡頭的高速主軸
- ❑ 為快速改裝機床優化的平衡系統
- ❑ 堅固且防水
- ❑ 單、雙平面 平衡演算法
- ❑ 嵌入式AE傳感器

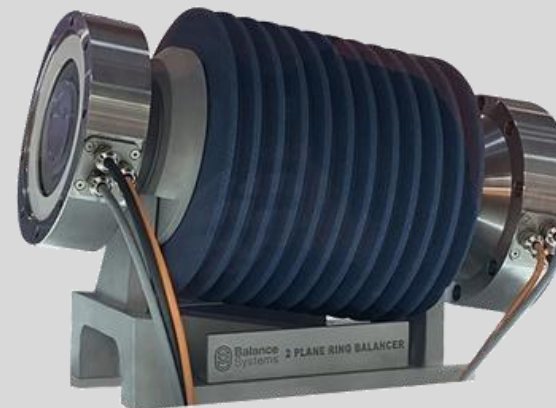
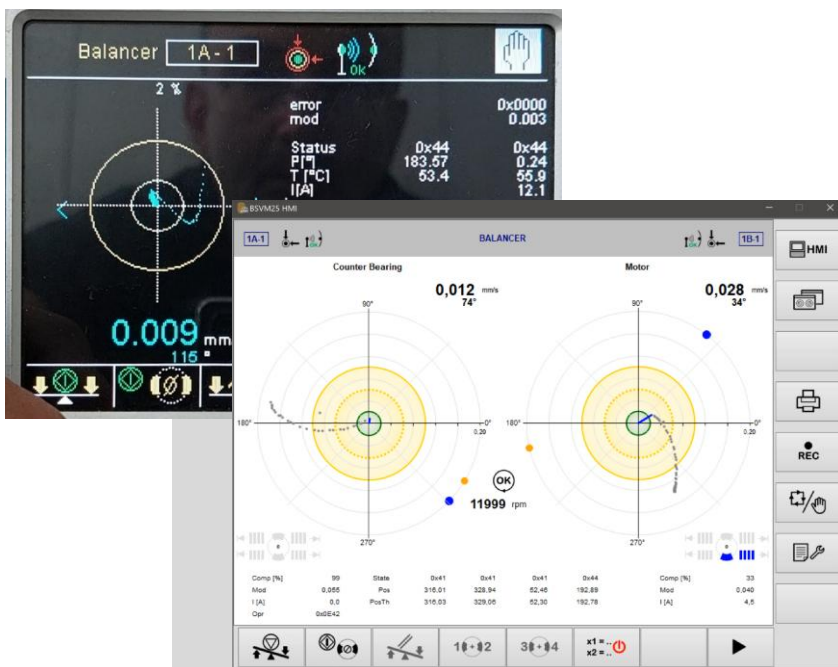
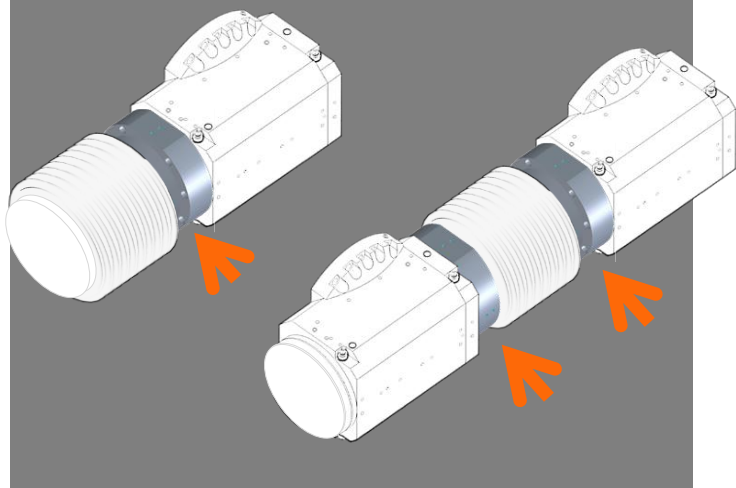

Features

- 為了控制振動並保持在安全範圍內而存在
- 平衡週期迅速且精確
- 適用於高速主軸 (up to 25.000 rpm)
- 不平衡狀態持續受到監測，並即時向控制器發出代表不同定義的信號 (警告或報警)，以實現安全監控管理。
- 使用頻譜分析功能可以調查並預測機器組件的狀態。

Benefits



Quality

- 高精度輪廓和幾何形狀控制。持續的優質表現。
- 最佳表面處理效果 (無振動痕跡)。減少廢品。
- 不影響相鄰的機器和設備，避免造成影響。



Lifetime

- 確保機台中最昂貴的零部件長久使用。
- 延長主軸壽命 (降低軸承和支撐部件磨損)
- 預防材料疲勞和故障。增加保養間隔時間。減少機器停機時間
- 避免砂輪安裝操作的時間和成本。無需在機器外進行預平衡。
- 防止砂輪磨粒斷裂。增加修整間隔。延長砂輪壽命。



Safety

- 可程式化的警報限制，以防止在振動過高時使主軸停機。
- 提供機器和使用者高度的保護。



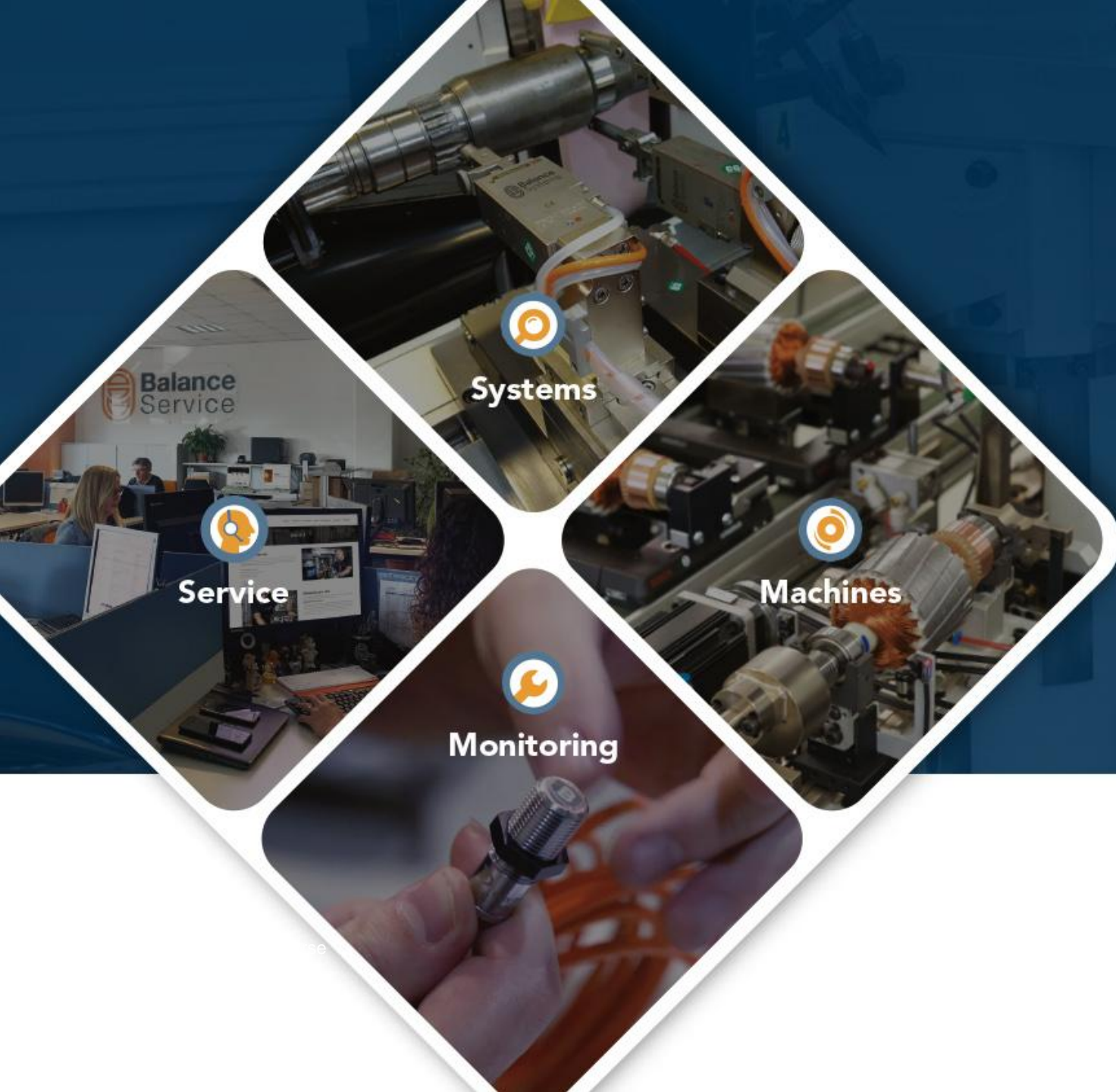

VM25 TOUCH DETECTOR

間隙防撞檢知

v.09.230228

**Your trusted partner
for balancing and grinding quality**

Process control and monitoring systems for machine tools and balancing machines for rotating components for over 50 years

What is the a touch detector ?

磨削是指工件的金屬表層被磨削，在無數砂輪磨粒瞬間的擠壓，摩擦作用下生產變形，而後轉為磨屑，並形成光潔表面的過程。過程可分為四個階段：

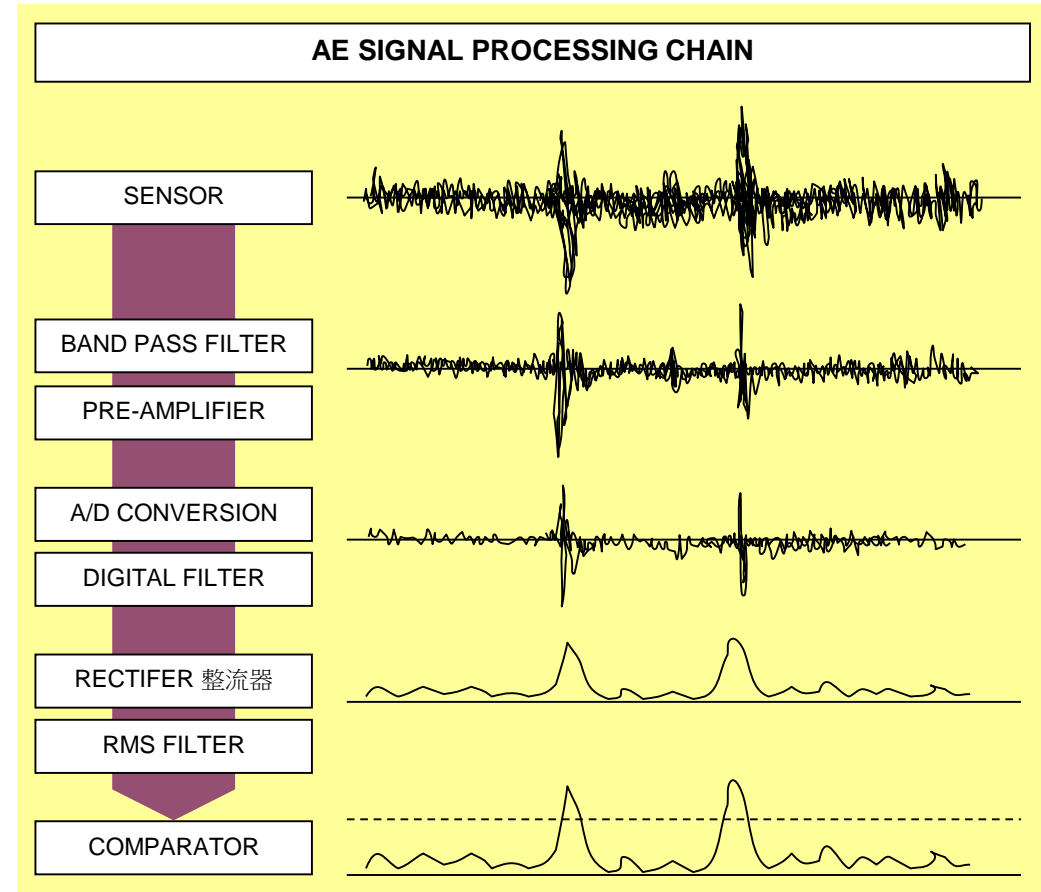
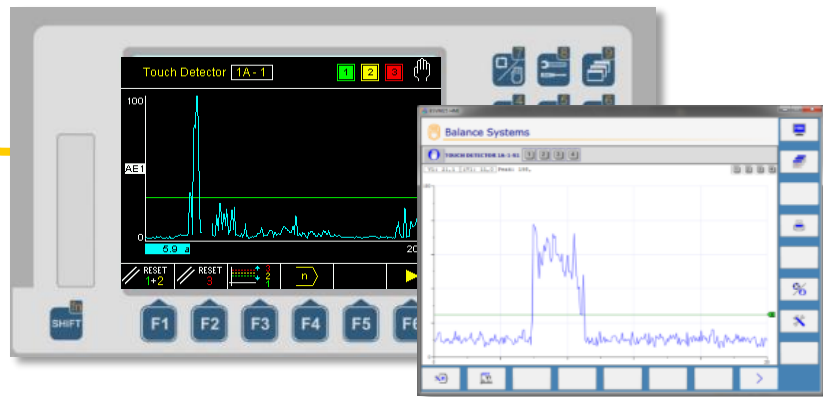
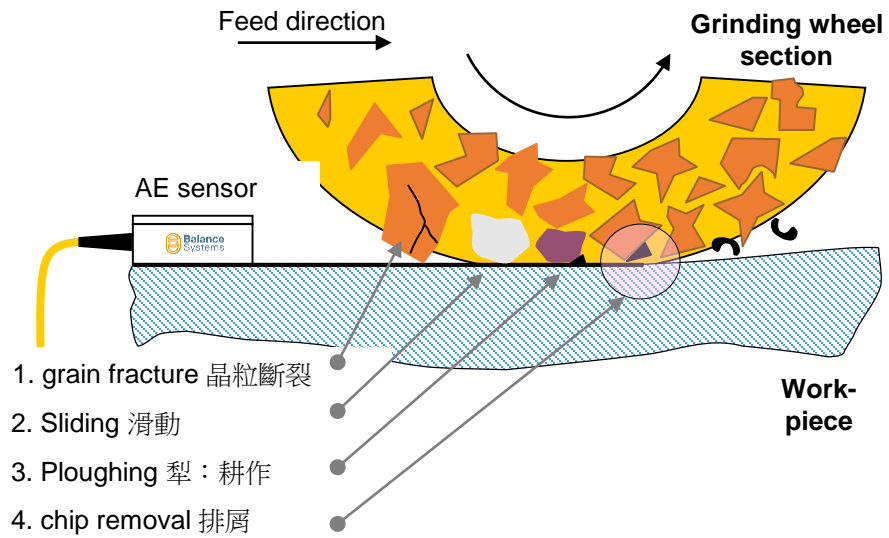

Method Based on Frequency Analysis (FFT)

- 砂輪與個別的工作之間實際上發生了什麼？
- 這些如何影響您的生產質量和整體生產力？

其實答案非常複雜，因為涉及到許多變數的交互影響！！！！

- 我們是否可以透過哪些線上監測，以改善質量和生產力呢？

我們可以提供：

- 
- **ACOUSTIC EMISSION** 音頻感應探測 (or AE, or Sound, or Noise)

- 
- **CONSUMED POWER** 功率負載偵測 (directly related to the Energy necessary to realize the process)

特別是以以下目標為主：

- 最小化“空磨削”時間
- 穩定研磨過程
- 減少(最小化)不必要的修整 (增加砂輪和工具的壽命)
- 預測並避免機器問題 (過切)

VM25 模組化之磨床線上多功能 系統

BALANCER



- 1 & 2 Plane Automatic Balancing
- Neutral cycle
- 1 & 2 Plane Manual Pre-Balancing
- Rotation Speed Monitor
- Frequency Analysis
- AE sensor for Gap&Crash
- Wireless technology

Control unit

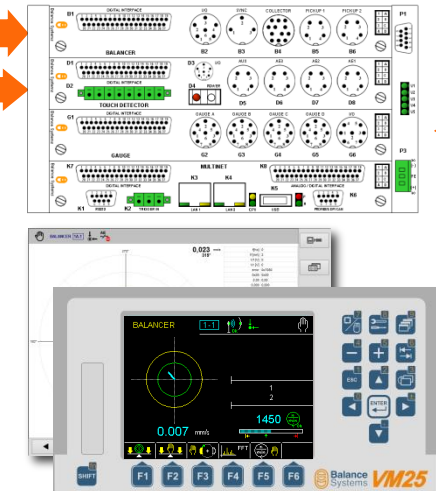

- Digital I/O
- Profibus DP
- Profinet RT I/O
- Control Panel HMI
- PC Windows HMI
- Remote control
- Service package

TOUCH DETECTOR



- Touch grinding control
- Dressing process control
- Anti-crash monitor
- Touch probe function
- Based on AE & Power sensor

GAUGE

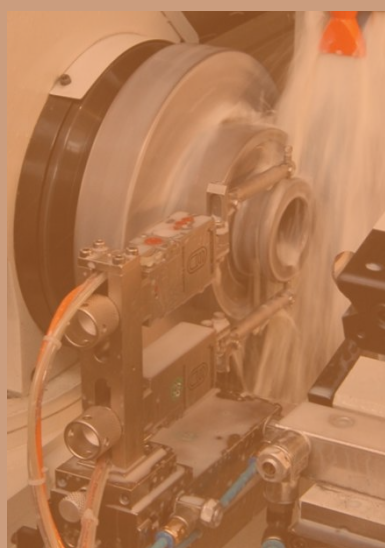

- Pre/In/Post-Process gauging
- Flagging
- Roundness & shape analysis
- Interrupted surfaces
- Wide range up to 25.4mm
- Anti-crash system
- Absolute gauge solutions



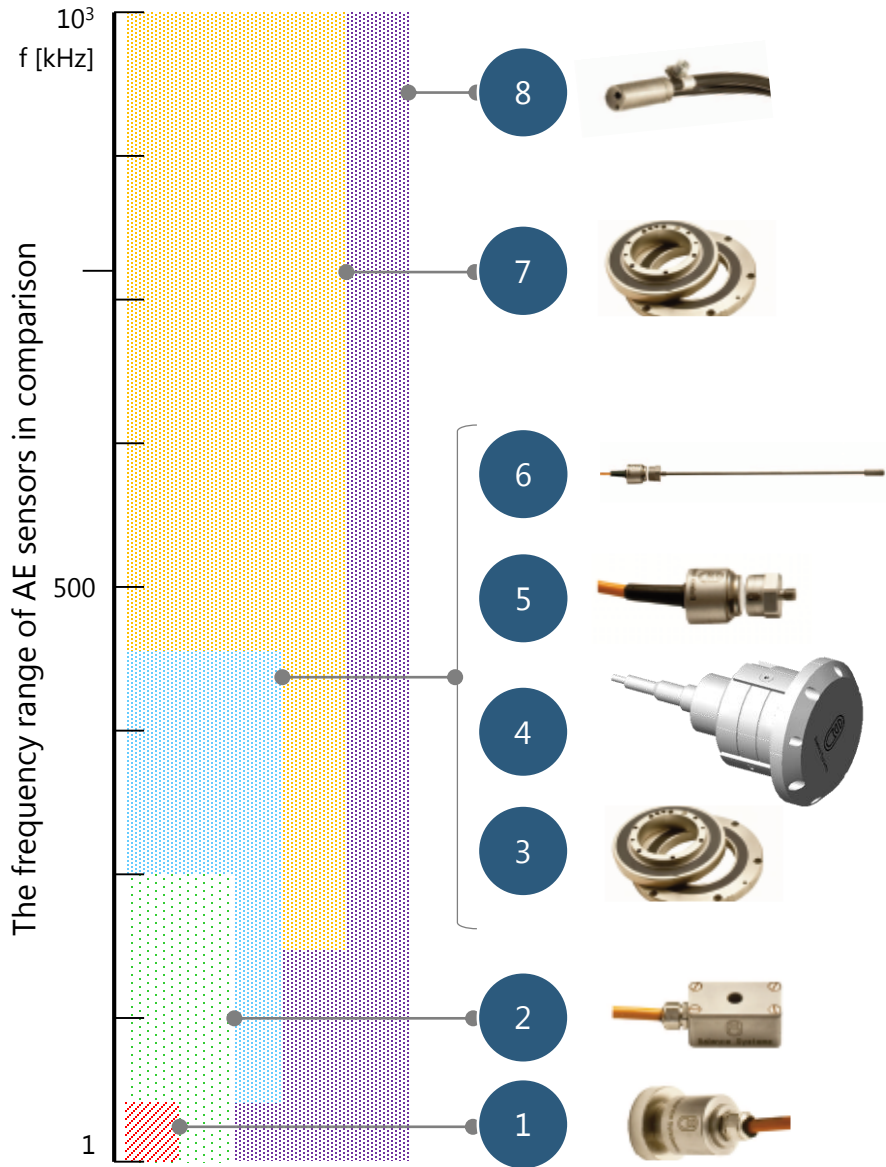

- Real time evaluation based on 3-phase voltage and current:

$$(v_i, i_i) \rightarrow p(t) = \sum_i v_i i_i$$
- High frequency sampling and 24 bits resolution vs 12 | 14 bits standard drivers
- High noise immunity thanks to digital conversion on source and connection by fiber optic
- Response time of the complete VM25 chain ≤ 2 ms
- Suitable for any motor type (AC 1Ph, AC 3Ph, DC)

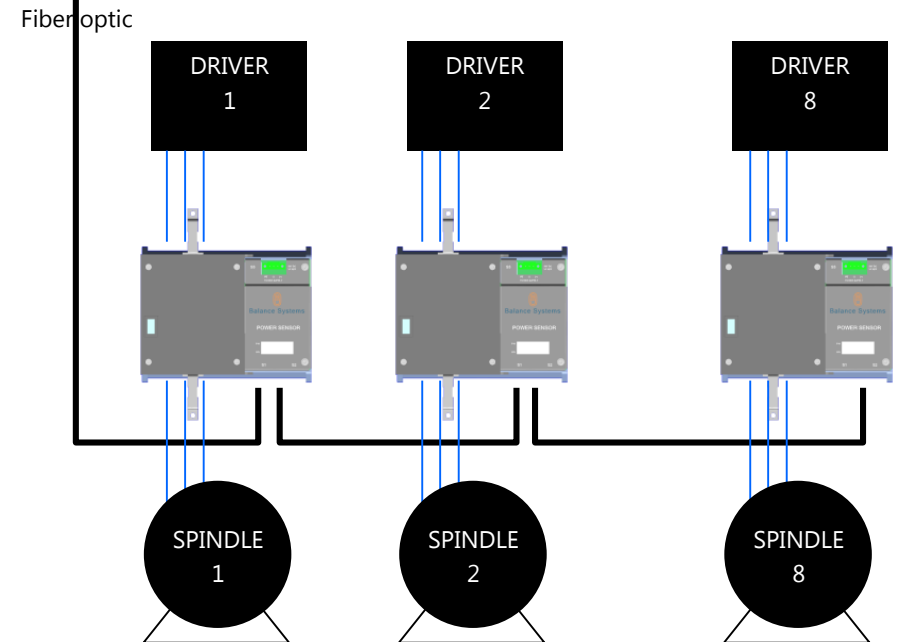
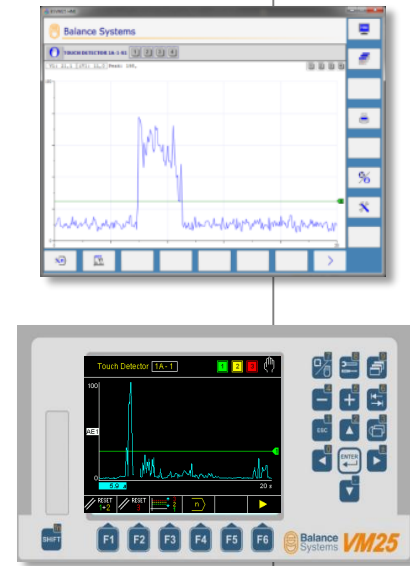
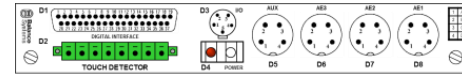
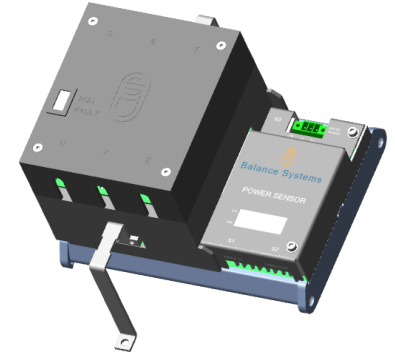

應用範例說明

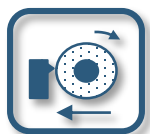

防撞監控

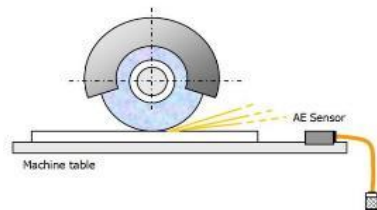
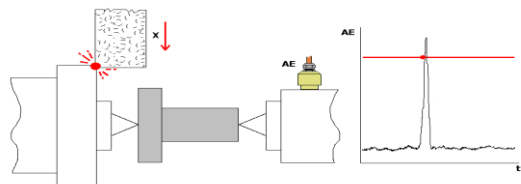

研磨接觸控制

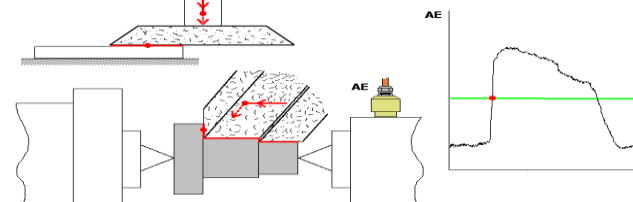

研磨接觸控制

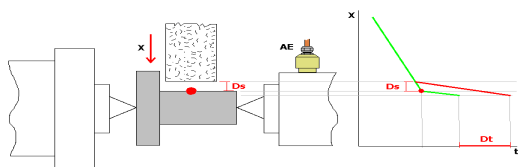

修砂接觸點探測

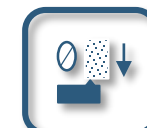
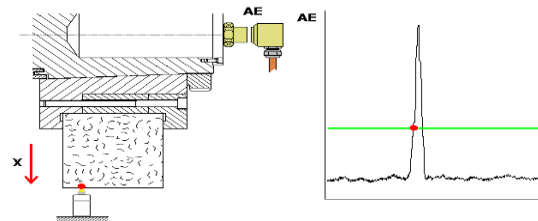

case of gear grinding ...

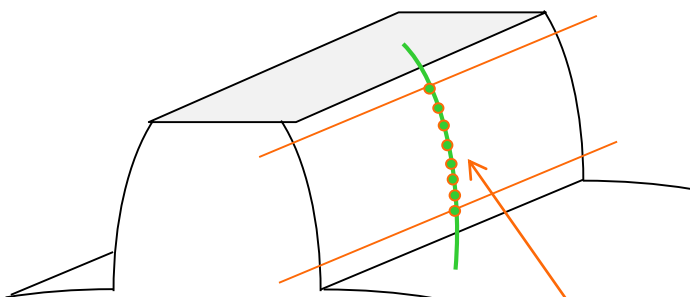

BEFNEFIT from DRESSING AIDED BY AE Sensor
Perfect SHAPE OF THE PROFILE

修砂完整性最佳化與形狀控制

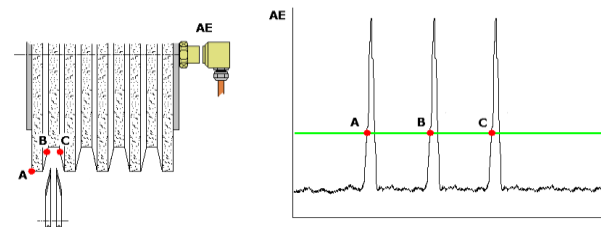

端點接觸功能應用

$$\text{Center} = (X2 - X1) / 2$$

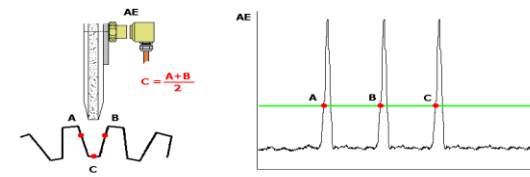

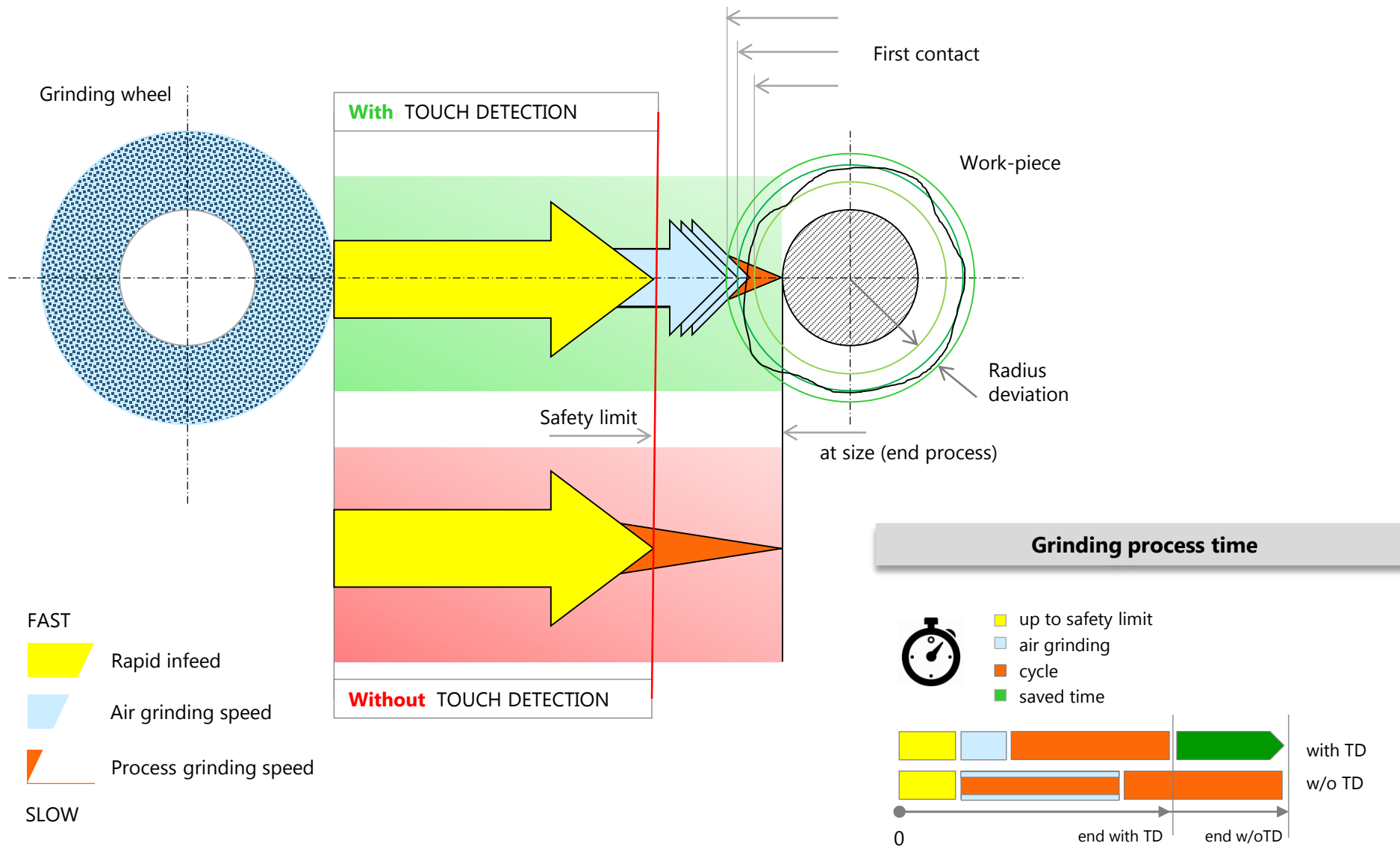
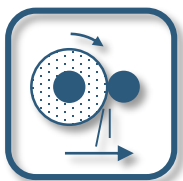

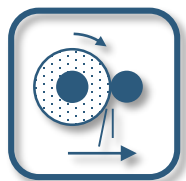

若無輔助檢測，在CNC機床中，從快速進給切換到工作進給速度的時機不容易定義，透過AE/或功率感測，在砂輪接觸工件時，隨即進行切換，令每個工件的加工週期時間可以顯著減少（高達30%）。

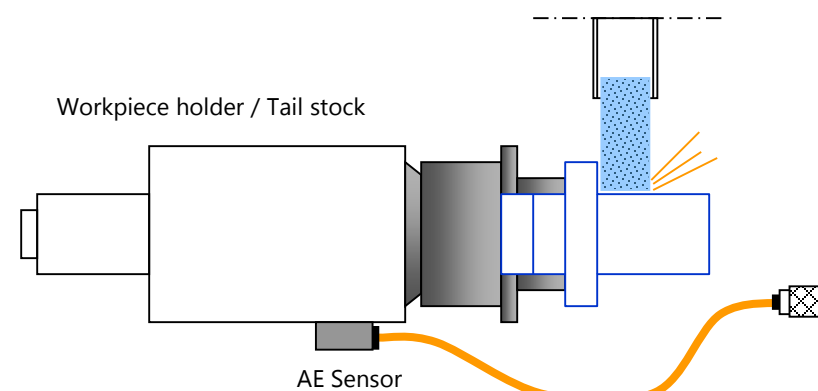
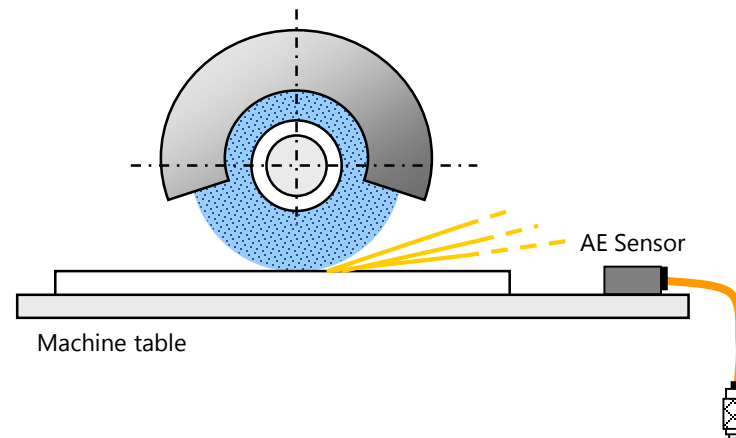
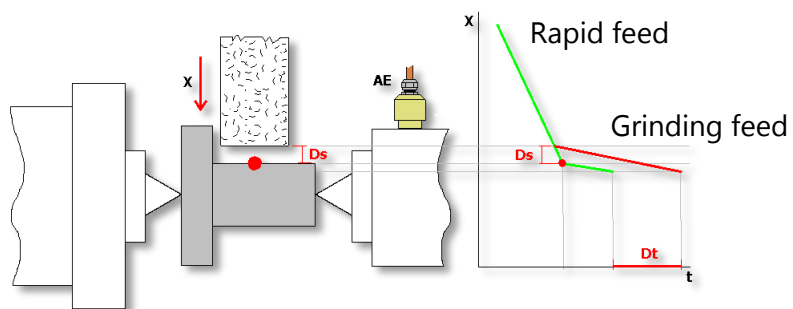

WATCH NOW



Touch

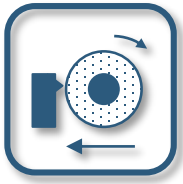

WATCH NOW



Carbon Fiber

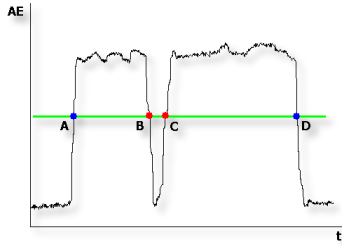
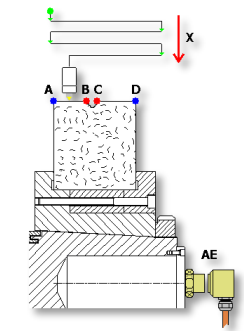

砂輪修整過程的**進給量與次數**，若沒有感測設備做輔助，一般應預先設置一定的修整深度，以便回復砂輪的消耗並確保將砂輪修整為新的平整切削邊緣。

這個過程可能導致砂輪過度消耗，尤其是在CBN砂輪的情況下，這**可能產生不容忽視的成本**。AE感測器可以確定砂輪與修整器的接觸狀態，以便設置正確的深度，透過確認修整AE信號是否高於預設的閾值準位，確保砂輪輪廓完整。

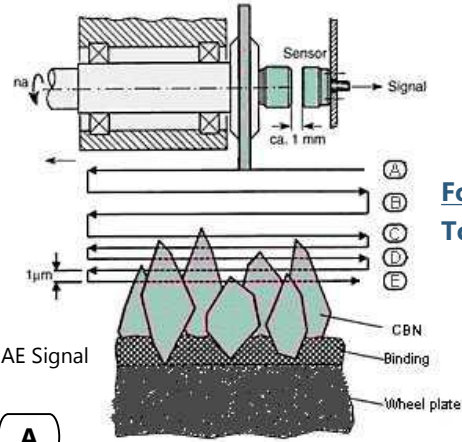

Formula:
Touch = N iv1 > 30.0

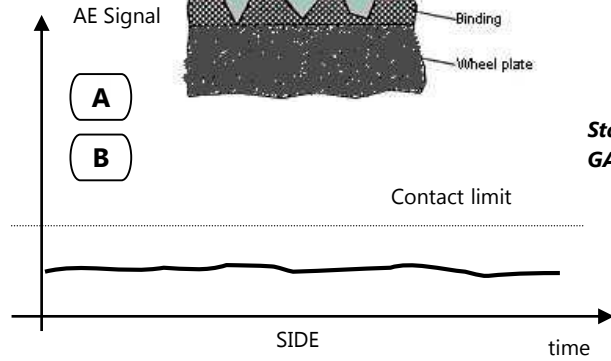

Start dressing
GAP ELIMINATION

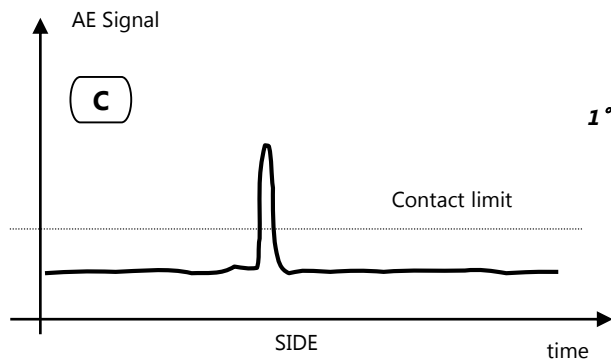

1° Contact

End dressing

Wait for continuous path...

Wait for continuous path...

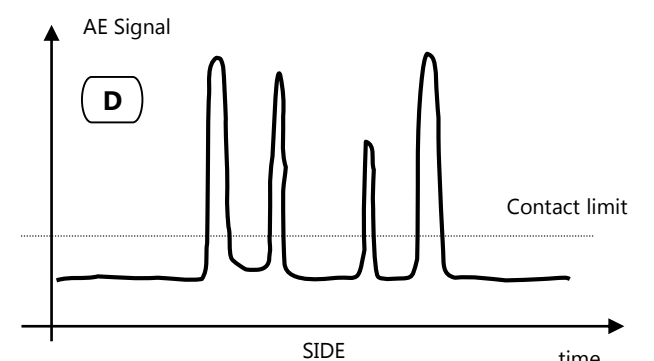
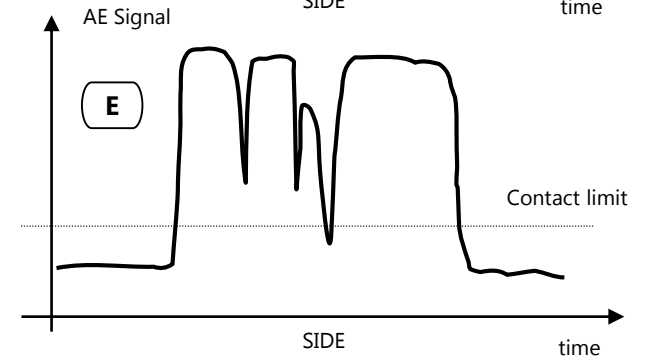
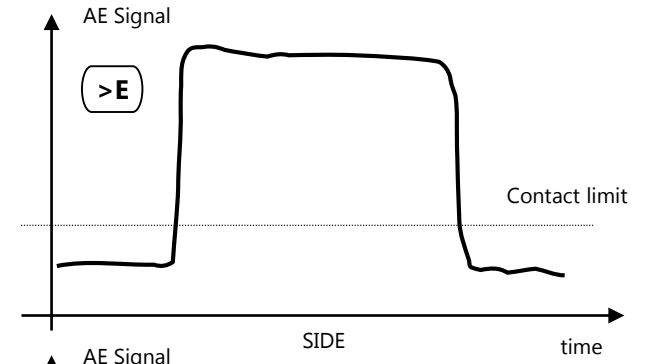

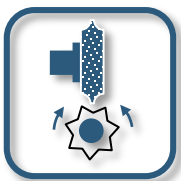

Overstock distribution. AE Sensor or Fluid sensor (Hydrophone - sensor based on coolant)

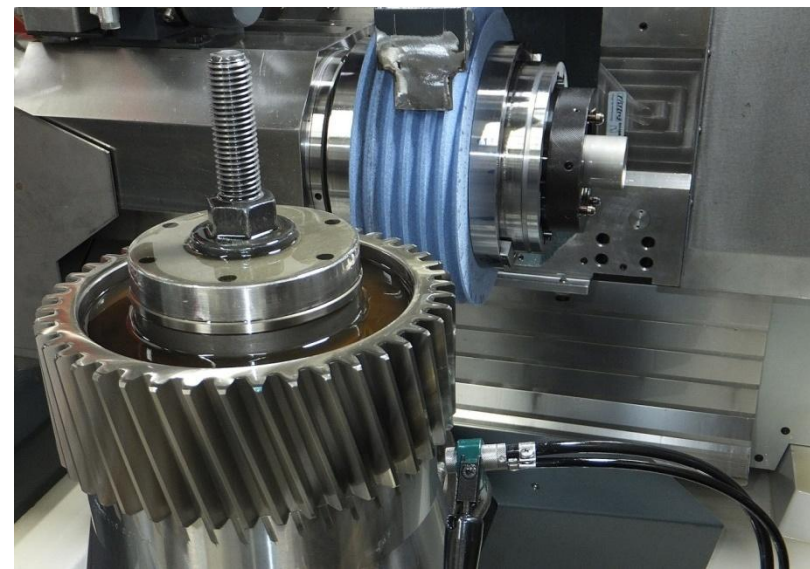
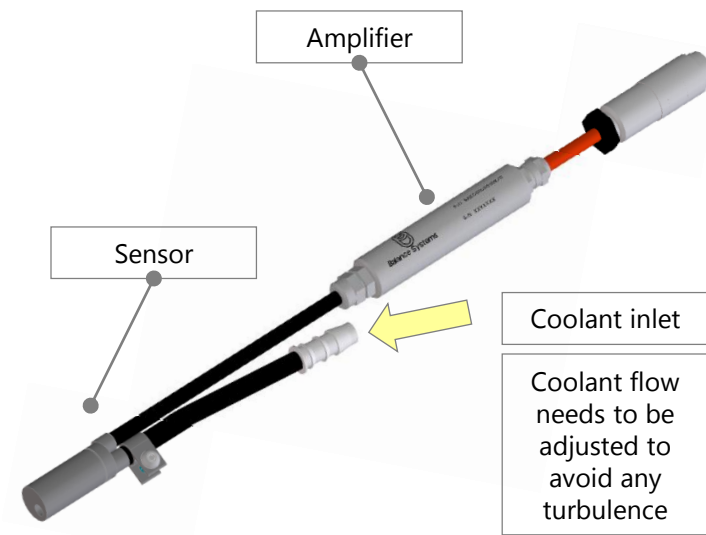
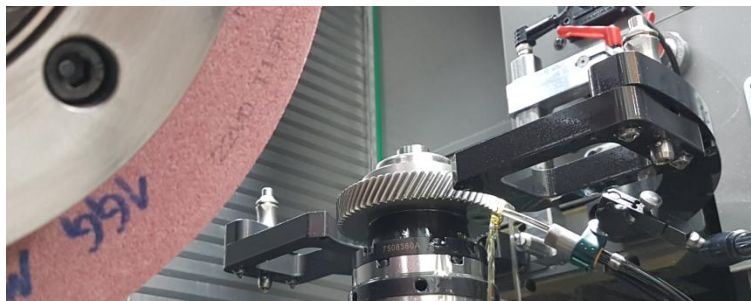
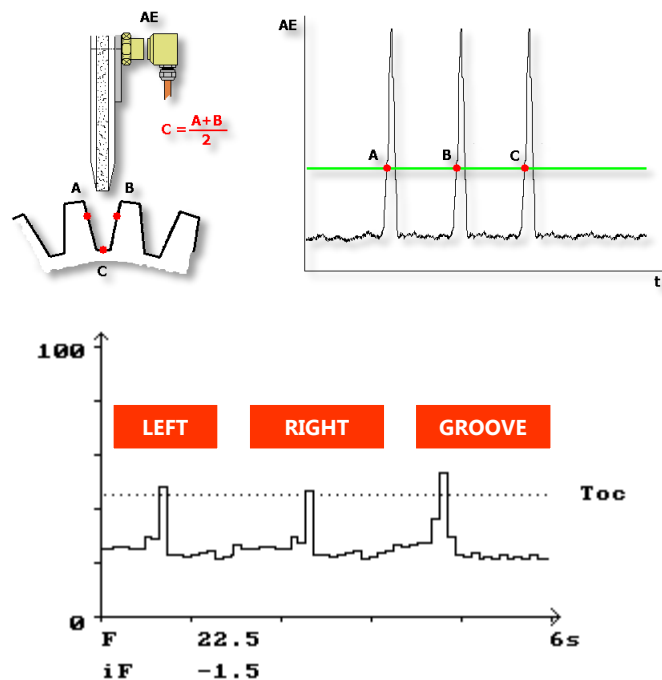



In case of part reworking or finishing with very thin overstock, it is essential to be able to position the wheel so that the removal is uniformly distributed regardless of the position changes of the part in the machine and of the available overstock. An acoustic emission sensor can detect more than one wheel-part contact thus allowing the CNC to determine centering and correct wheel movements.

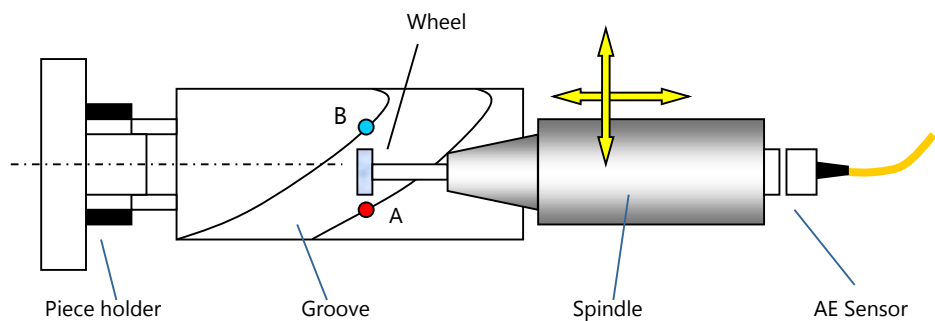
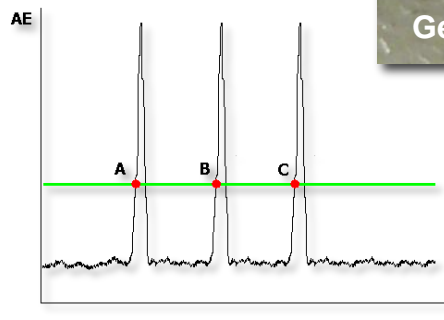
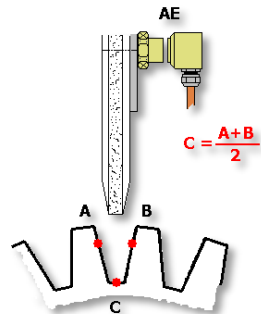
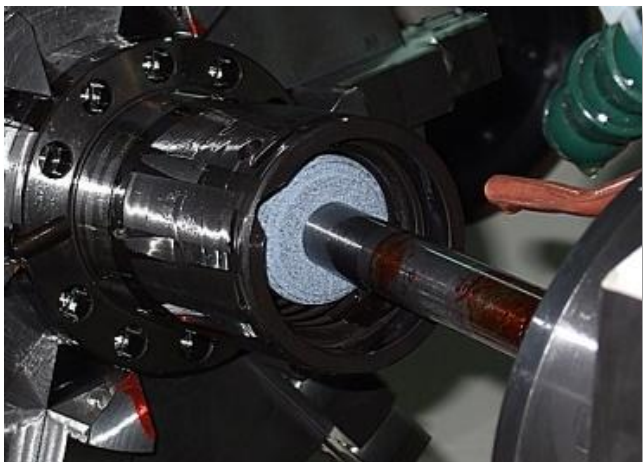

Centering

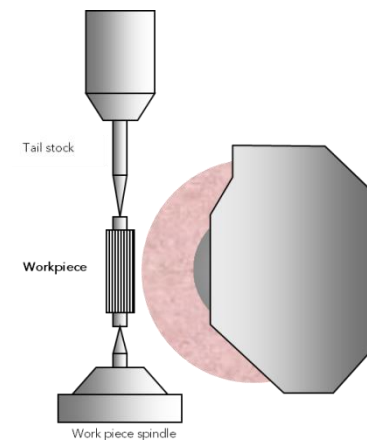
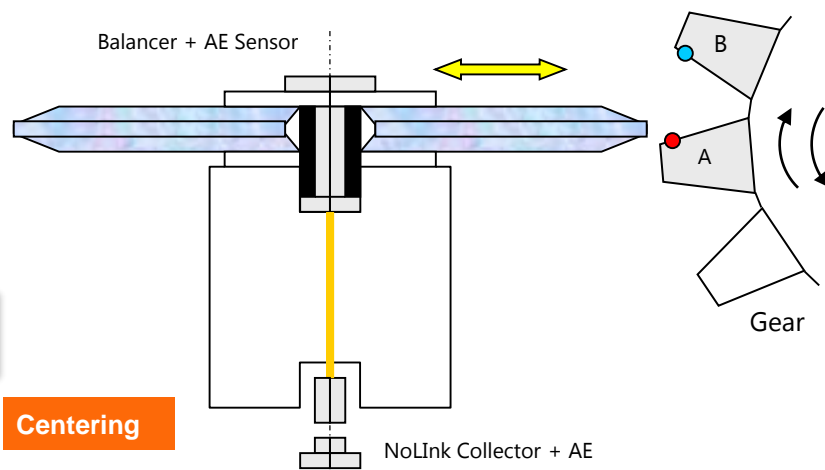

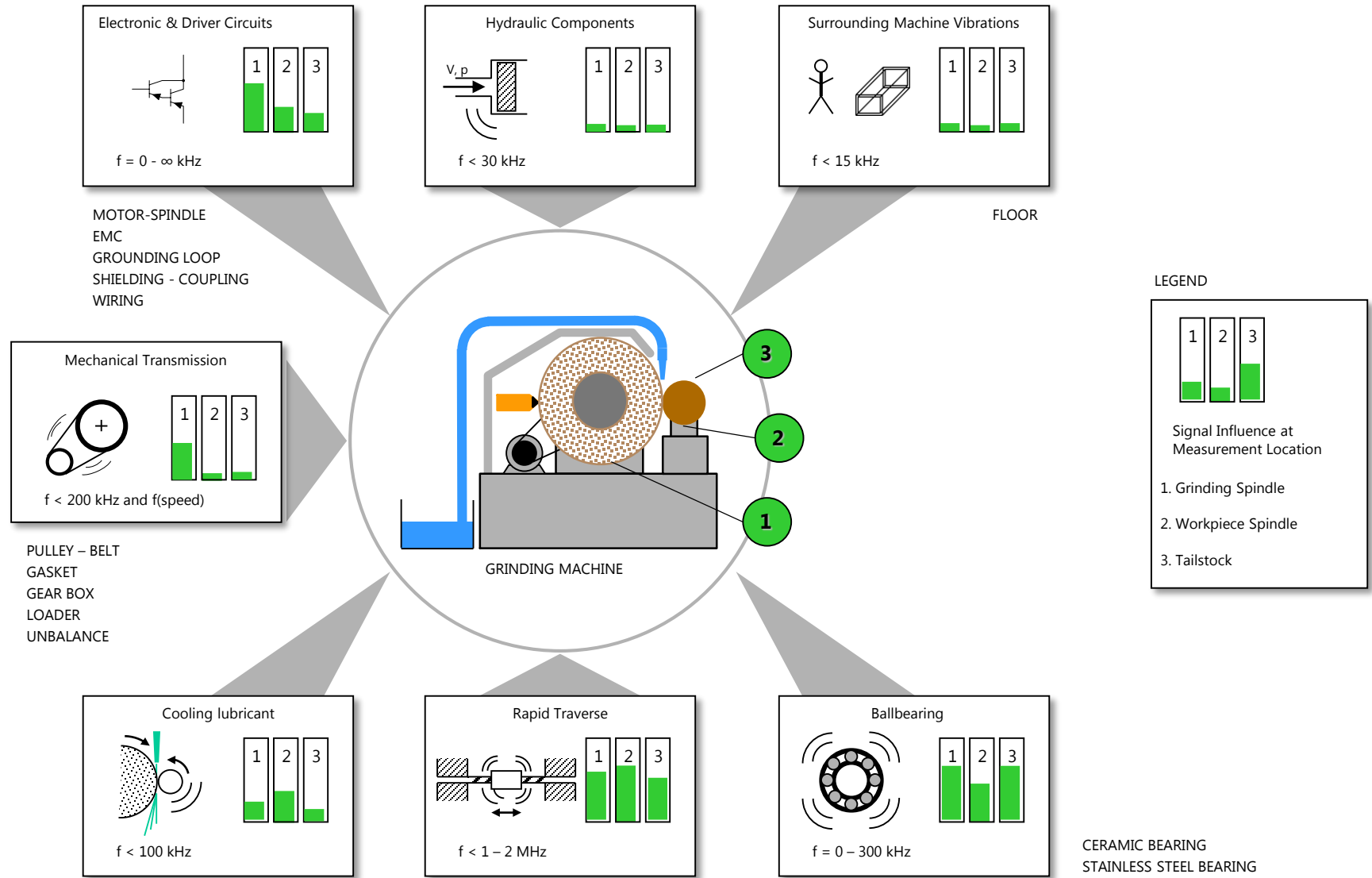

MOTOR-SPINDLE
 EMC
 GROUNDING LOOP
 SHIELDING - COUPLING
 WIRING

FLOOR

PULLEY - BELT
 GASKET
 GEAR BOX
 LOADER
 UNBALANCE

CERAMIC BEARING
 STAINLESS STEEL BEARING

How to identify the right AE signal ?

TIME DOMAIN

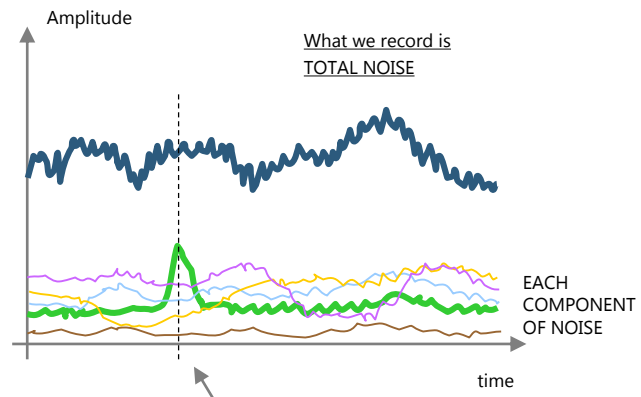

It is hard to identify
DESPERATE CRY
or
TOUCH GRINDING



The FFT changes
the point of view



FREQUENCY DOMAIN

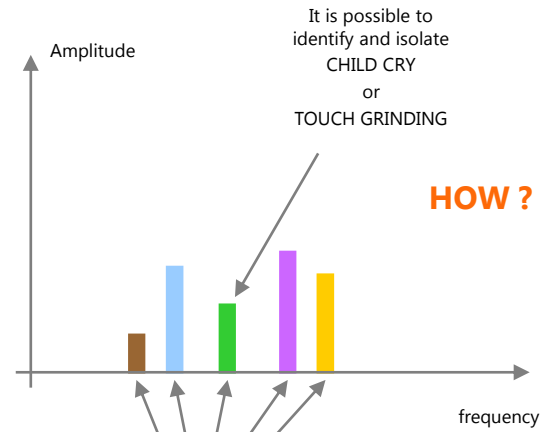

What we record is
EACH
COMPONENT OF
NOISE

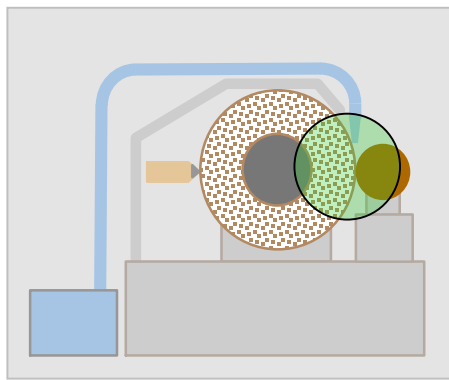

GRINDING MACHINE

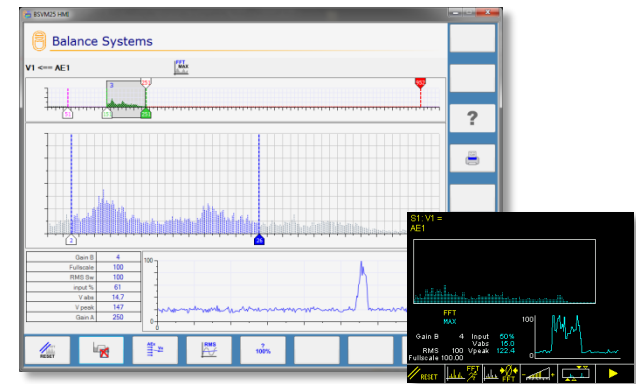

How to identify the right AE signal ?

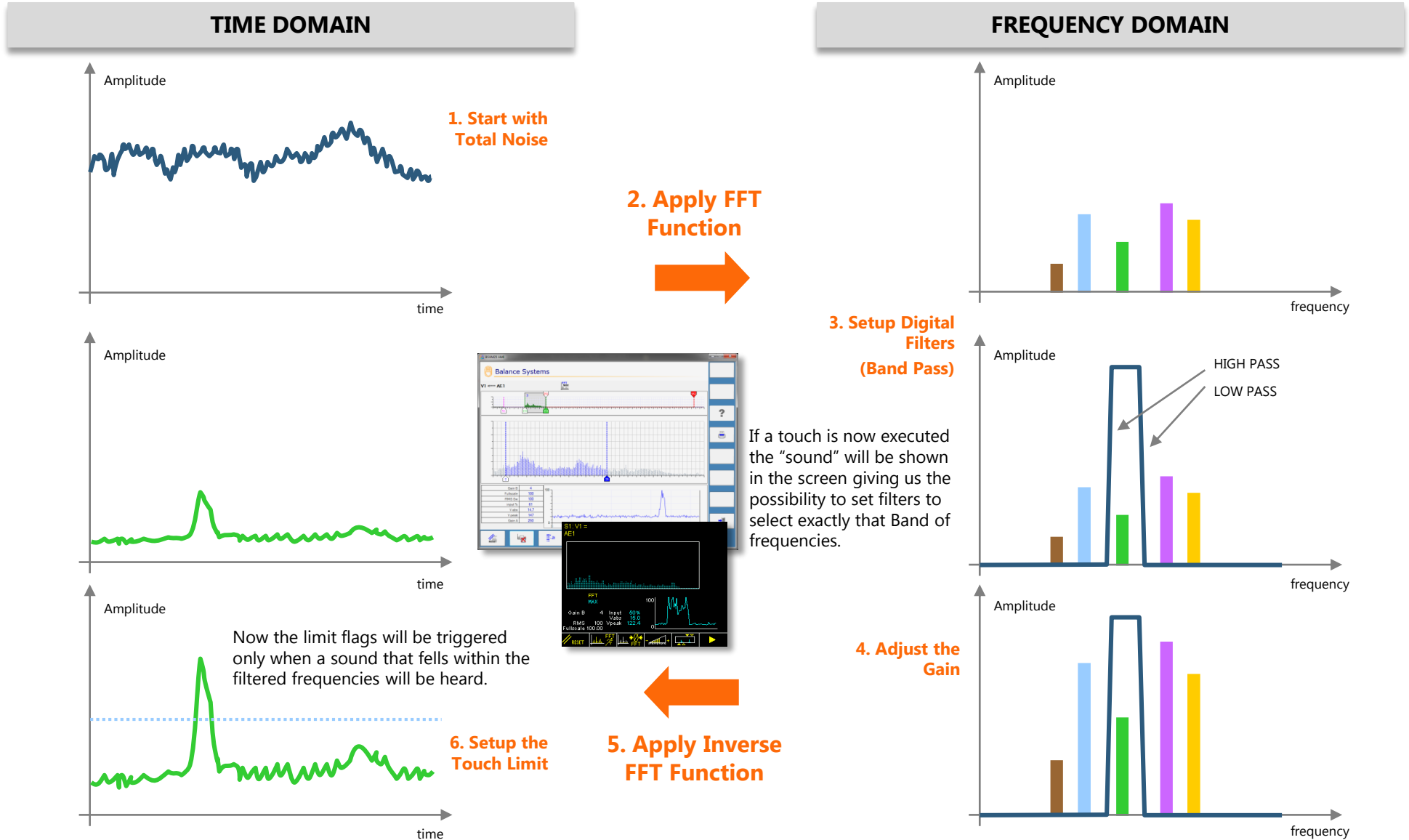

If a touch is now executed the "sound" will be shown in the screen giving us the possibility to set filters to select exactly that Band of frequencies.

➔

➔



Description	Mounting
AE Ultrasonic	Magnet/Screw
AE Single Point	Screw
AE Axial (contact less)	Spindle nose
AE Radial (contact less)	Spindle nose
AE Ring (contact less)	Spindle body
AE Remote (contact less)	Built-in spindle
Embedded in Balancer (contact less)	Built-in spindle
AE Fluid sensor (Hydrophone)	Work area
Power sensor	Spindle body

頻率分析與選擇信號擷取範圍
響應時間 < 1ms

FFT 雜訊過濾功能

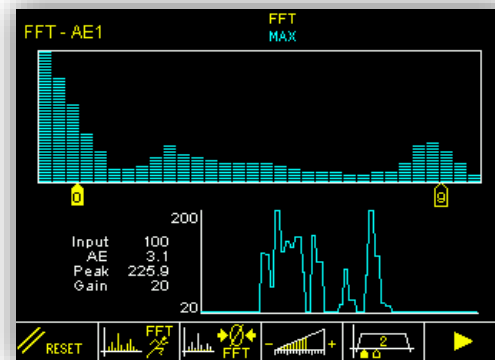

- Sensor Setup Based on Frequency Analysis
- Multi-Band Digital Filtering / Noise suppression

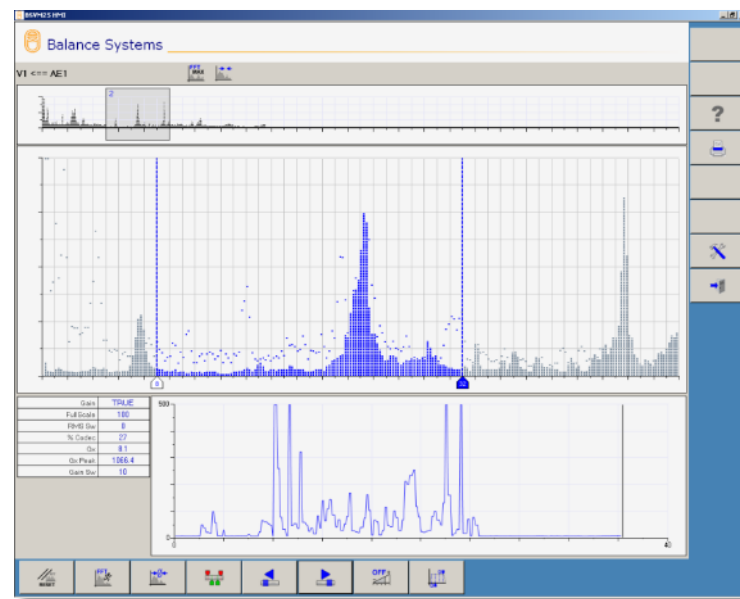

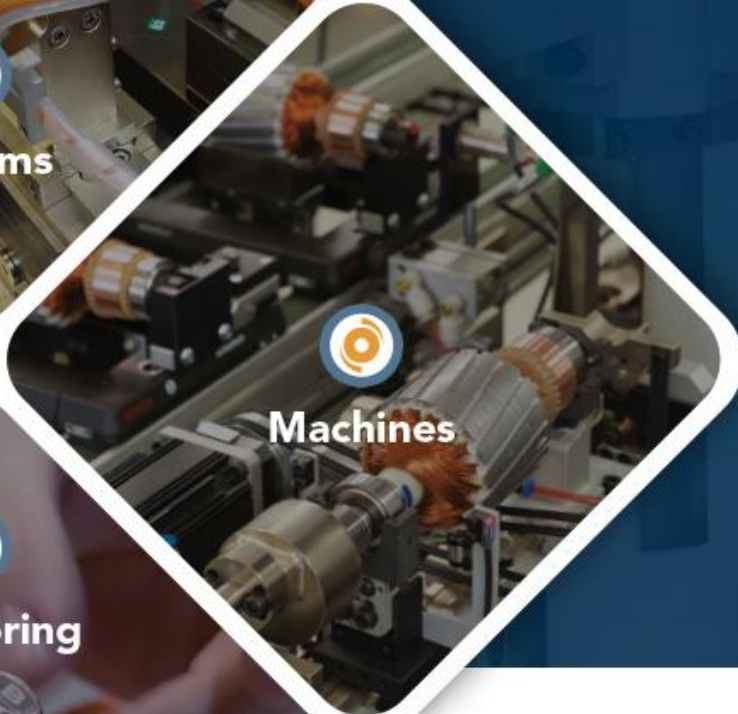

ENVELOPE

幫助加工 研磨細部過程監控，並標準化研磨效率和協助分析加工過程。

幫助減少砂輪修整時間，並延長輪廓和標準化砂輪的壽命。

它可以利用當前AE或功率過程信號，與已知的經良好修整而得出的主要形狀進行比較，以確定並報告修整過程是否成功完成，從而最大程度地提高修整過程的效率和形狀。

透過教導系統一個成功修整過程的AE或功率波形，能夠創建標準樣本形狀。

系統會自動學習整個過程，並將其分成數個（參數）“區域”，在屏幕上以柱狀圖形表示。

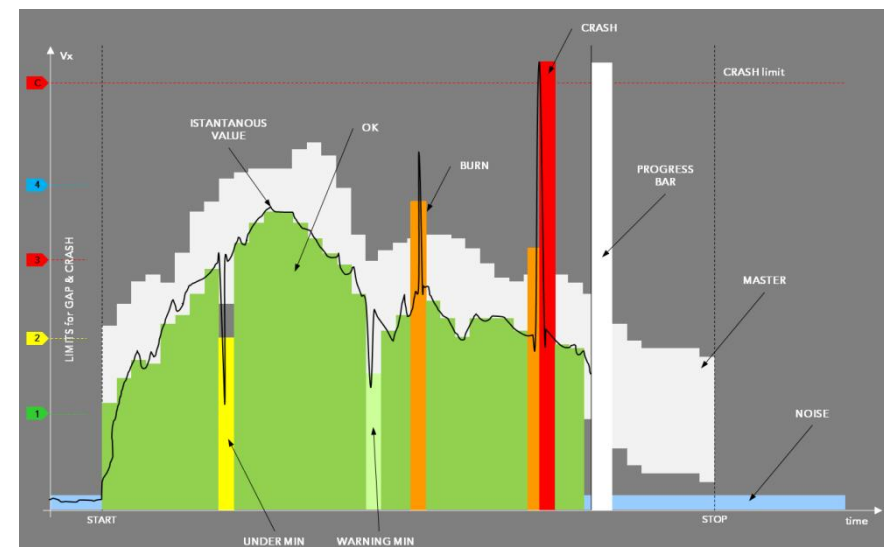

- 確定研磨過程均按照正確定義的負載進行
- 確定砂輪是否按照正確定義的形狀進行修整
- 控制 研磨\修整 過程的安全性
- 保持修整砂輪的質量，同時優化過程時間並節省砂輪材料

- **Gray.** Learned Master shape shown in background
- **Green.** Zone matches the master
- **Light Green.** Borderline zone nearing lower limit
- **Yellow.** zone below lower shape
- **Orange.** zone over higher shape
- **Red.** zone over Crash limit
- **Blue.** Zone below the Noise level

Envelope function – Editing a MASTER shape

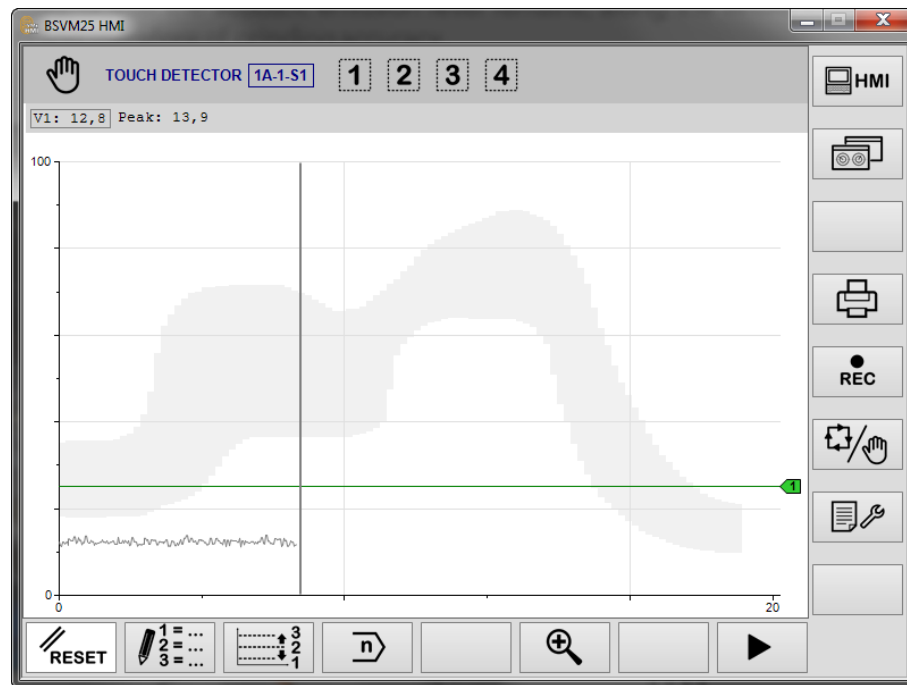
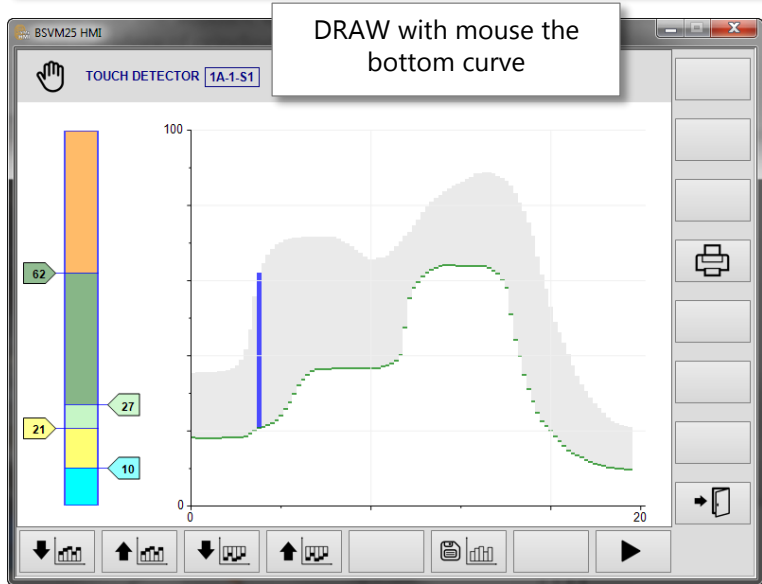
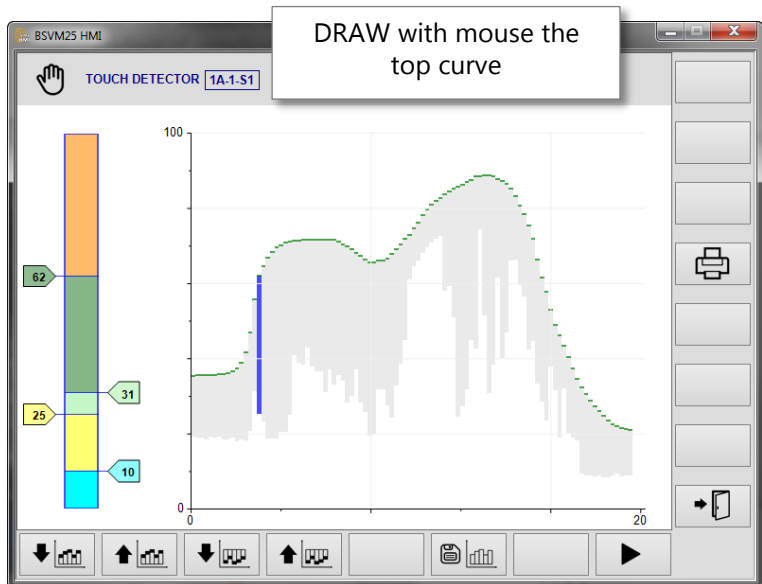

Master shape
Ready to be used

WATCH
NOW



Master editing

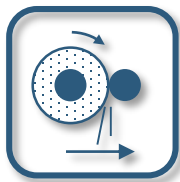

AE Signal while the dressing cycle is in progress

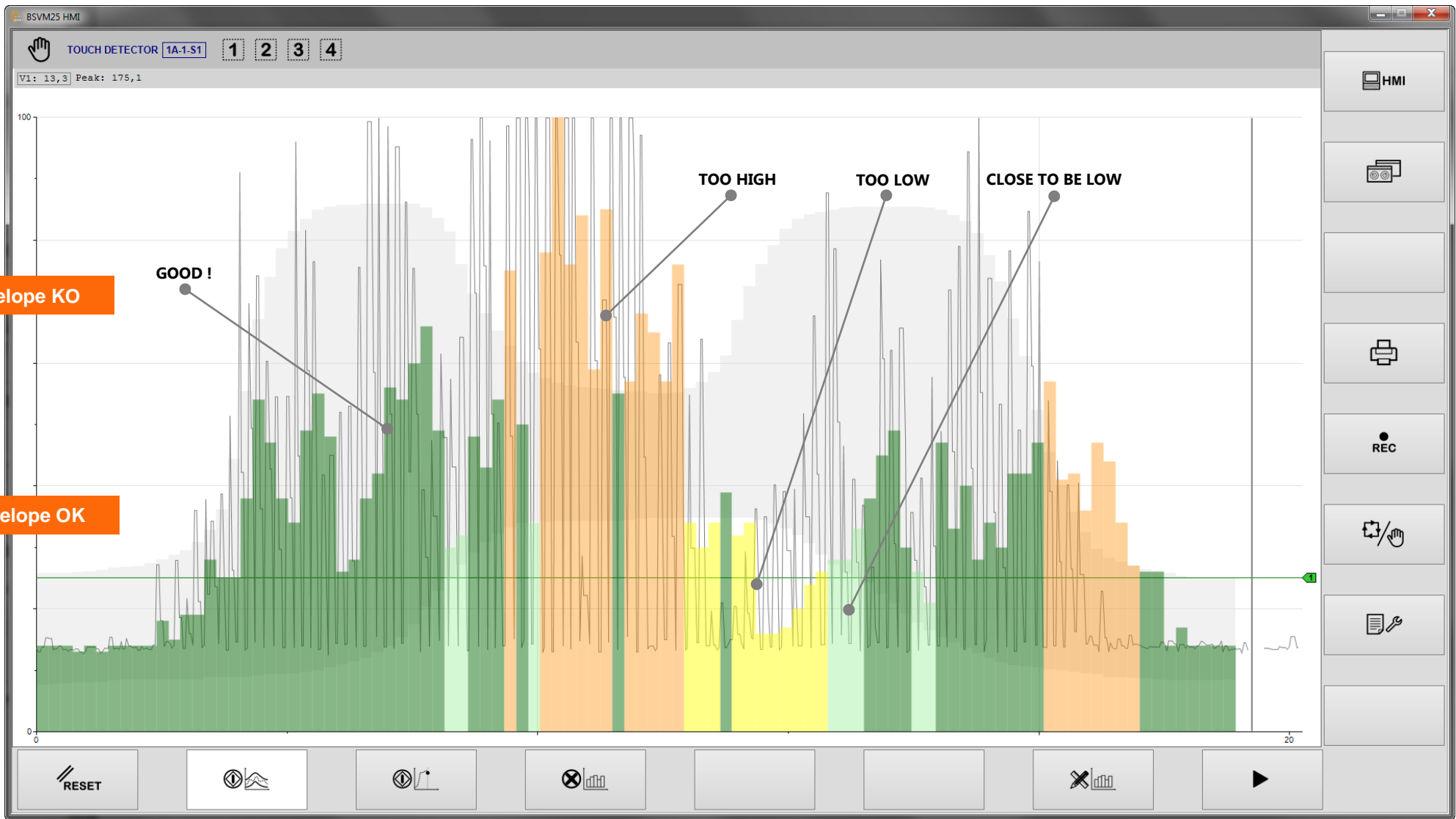

Features & Benefits



- 檢測砂輪和工件的接觸點
- 消空行程，節省時間
- 優化修整週期，達到最佳的砂輪輪廓和最少的材料去除
- 修整時對砂輪形狀的堅控，達到完美的砂輪輪廓
- 可編程的檢測準位
- 監視和碰撞檢測
- 靈敏度 <math> < 0,5 \mu\text{m}</math>，響應時間 <math> < 1 \text{ ms}</math>
- 對電磁影響（EMC干擾）具有高度的免疫性

**Productivity****Quality****Lifetime****Safety**

- 減少機器停機時間
- 縮短加工週期時間
- 減少廢品
- 保護主軸
- 增加砂輪壽命（對超硬材料非常重要）
- 增加修整部件壽命
- 保護人員安全



- 透過哪三種功能的應用，能提升磨床加工的品質、效率，並延長砂輪壽命並兼顧使用安全性？

砂輪自動平衡、接觸探測與線上量測。

- 接觸點探測功能技術，有哪兩種？

音頻感應探測 與 功率負載偵測。

- 音頻感應接觸點探測功能響應時間為？

響應時間 < 1ms。



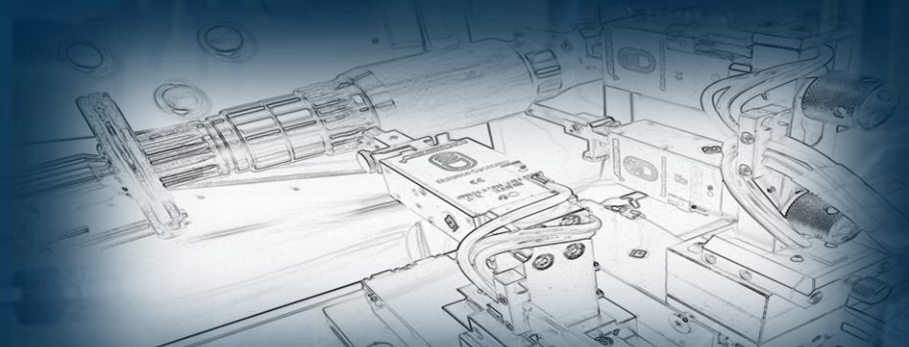
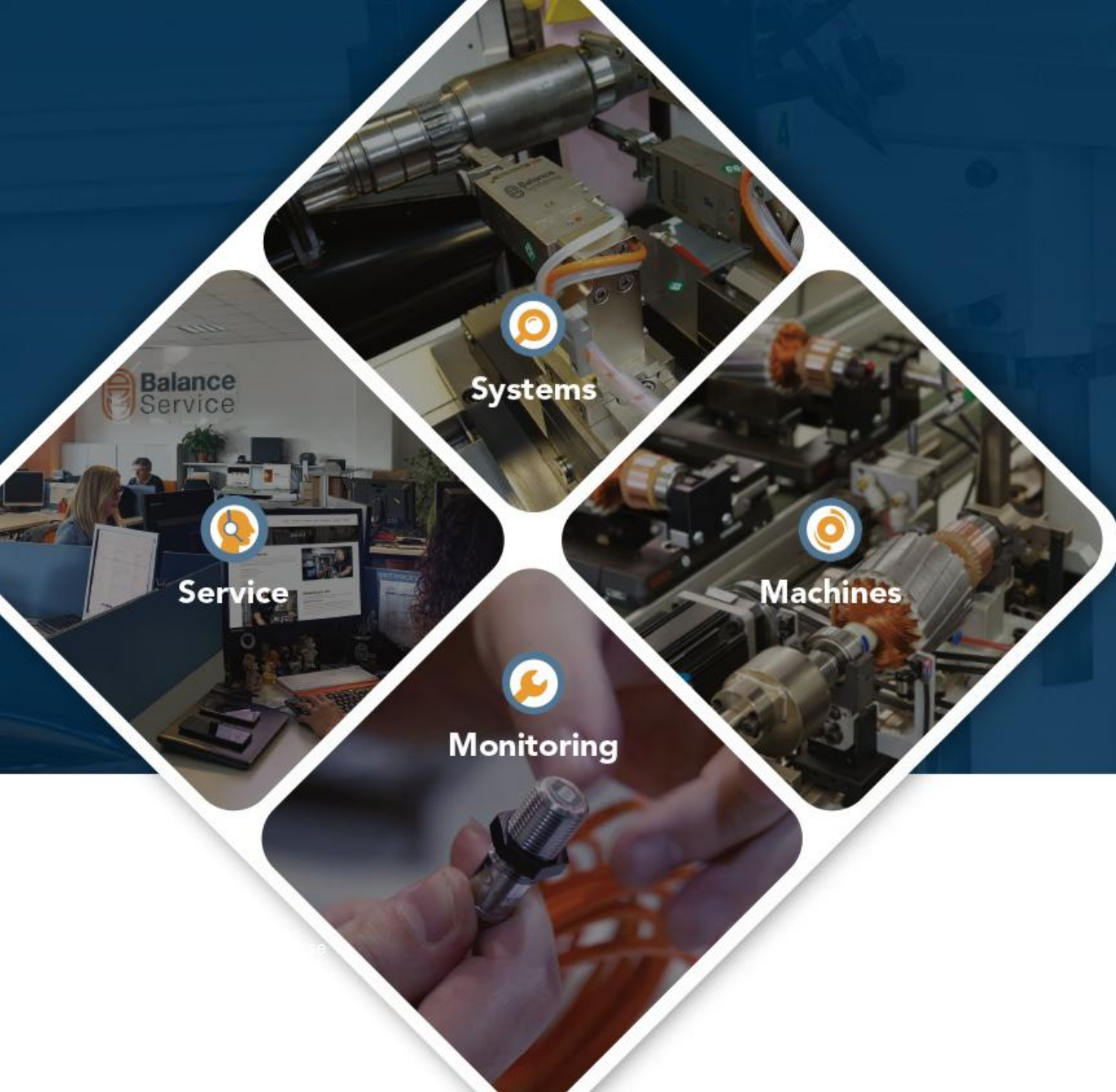

VM25 GAUGE
線上\外量測
v.07.230215

**Your trusted partner
for balancing and grinding quality**

Process control and monitoring systems for machine tools and
balancing machines for rotating components for over 50 years

USync
心得科技工業股份有限公司

主講人: 陳協輝 課長



- 砂輪磨損以及加工機和零件溫度變化，尤其是瞬間狀態下，無法將零件尺寸控制在精密的公差範圍內。
- 透過適當的閉迴路控制，線上自動化量測解決方案可以實現穩定的生產質量和週期時間的改進。
- 在加工過程中量測零件可以提供有關影響加工能力的變量訊息，例如尺寸、形狀、硬度、砂輪鋒利度。

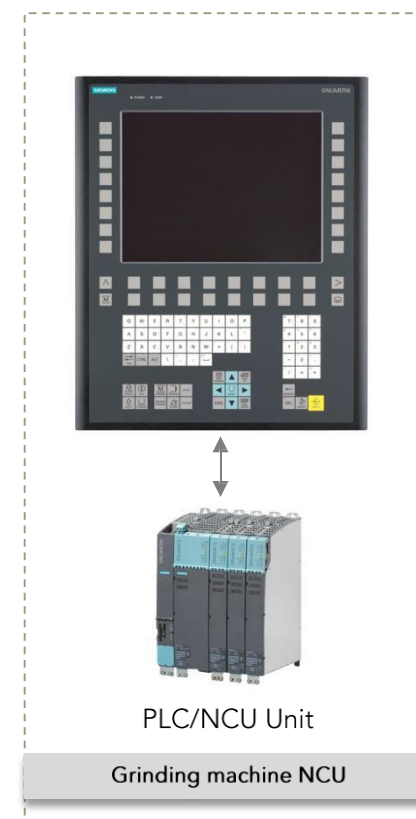
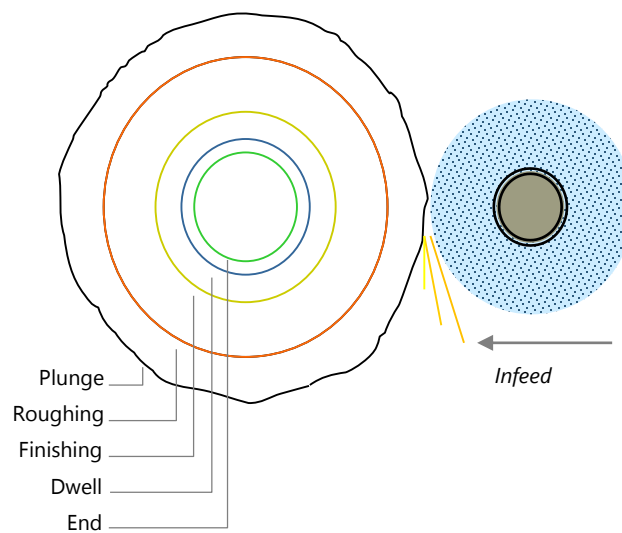
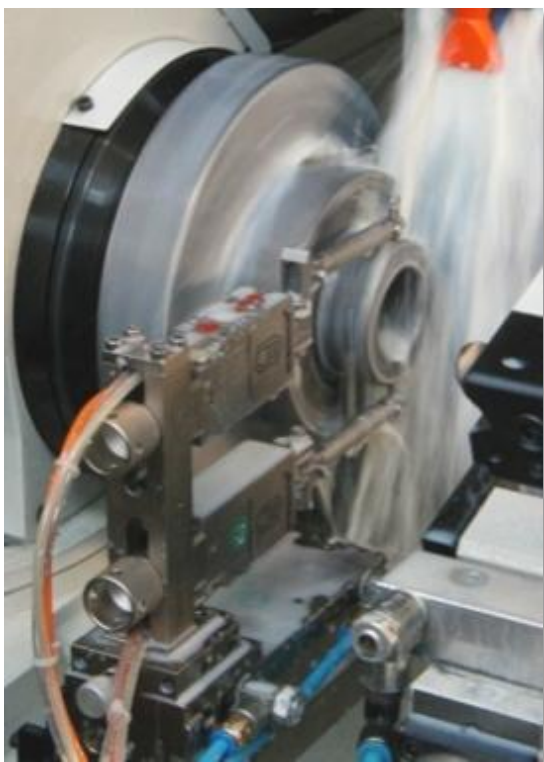

VM25 模組化之磨床線上多功能 系統

BALANCER



- 1 & 2 Plane Automatic Balancing
- Neutral cycle
- 1 & 2 Plane Manual Pre-Balancing
- Rotation Speed Monitor
- Frequency Analysis
- AE sensor for Gap&Crash
- Wireless technology

Control unit

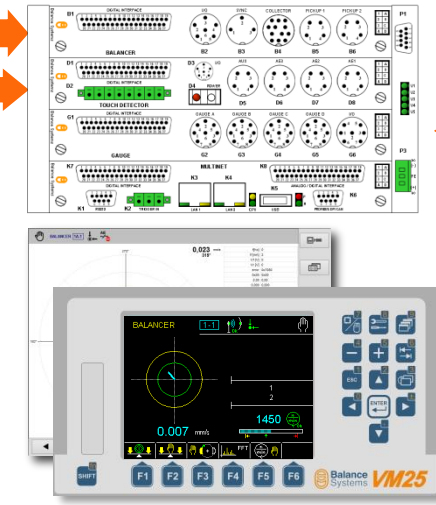

- Digital I/O
- Profibus DP
- Profinet RT I/O
- Control Panel HMI
- PC Windows HMI
- Remote control
- Service package

TOUCH DETECTOR

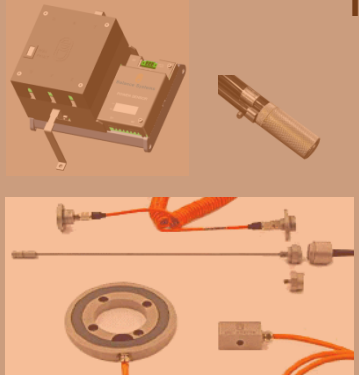

- Touch grinding control
- Dressing process control
- Anti-crash monitor
- Touch probe function
- Based on AE & Power sensor

GAUGE

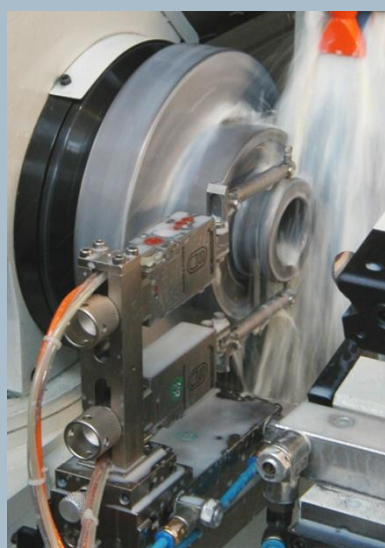

- Pre/In/Post-Process gauging
- Flagging
- Roundness & shape analysis
- Interrupted surfaces
- Wide range up to 25.4mm
- Anti-crash system
- Absolute gauge solutions



The feed-back concept

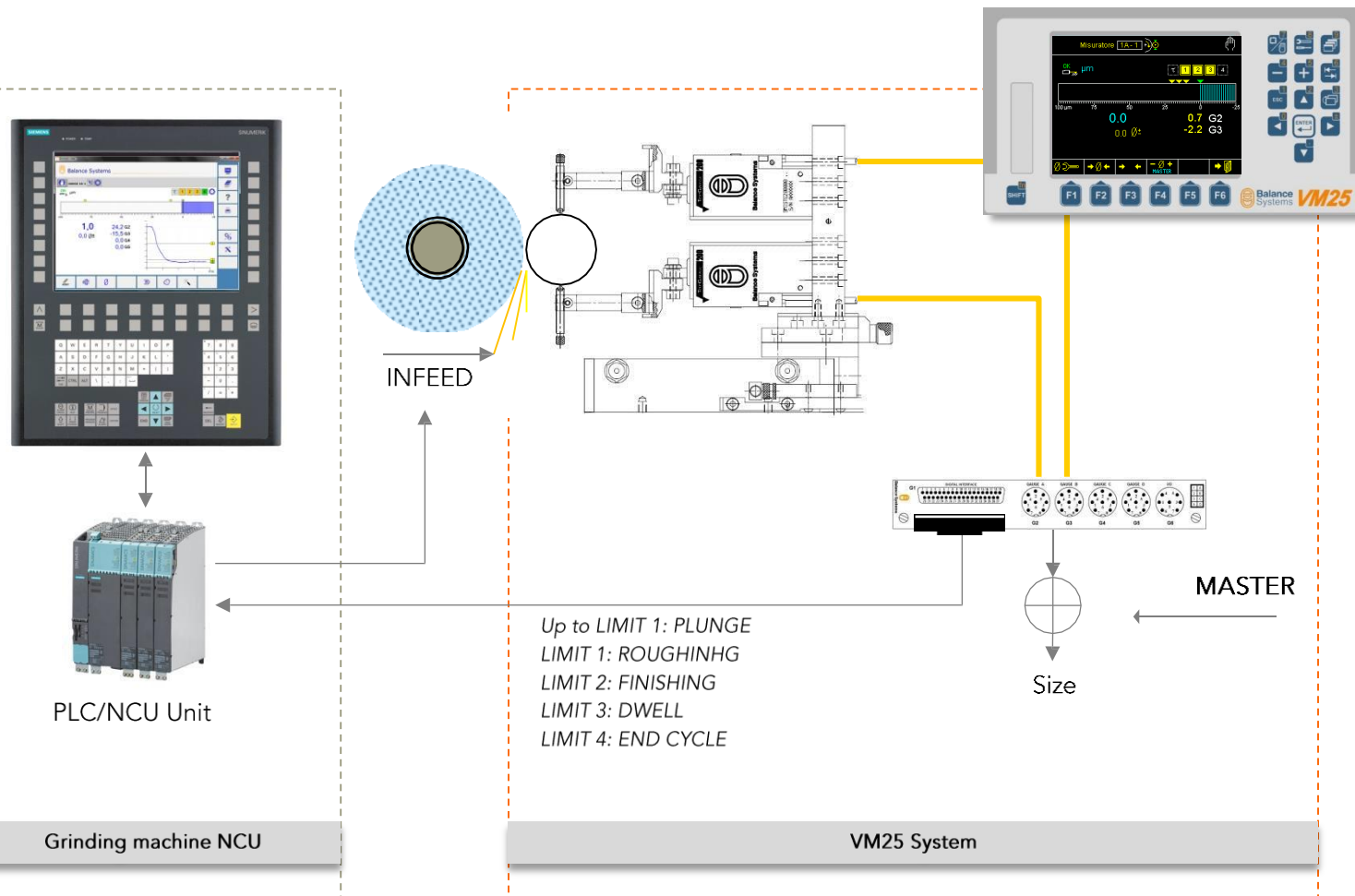

VM25可以透過研磨過程量測監控，向磨床CNC發出訊號命令，控制研磨參數變化，優化研磨流程。

當量測系統無法在加工中量測時，VM25測量儀可以設定模式在前後處理下使用，自動將修正參數發送至磨床CNC，以保持過程受控。

這個量測系統是一個比較系統，不是絕對式，他需要一個標準件進行零點參考，作為磨削過程的目標點。

- In-Process Feedback: 過程中反饋，零件在加工過程中量測，機械可以實時進行動作變更。
- Post-Process Feedback: 零件在磨削過程後測量，機械將針對下一個零件進行校正(例如無心磨床)

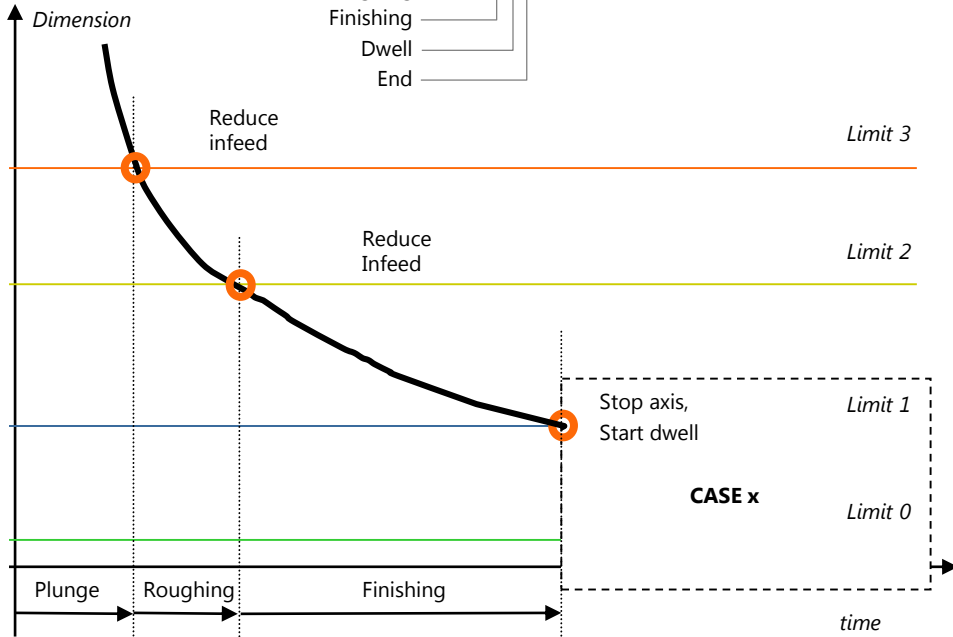
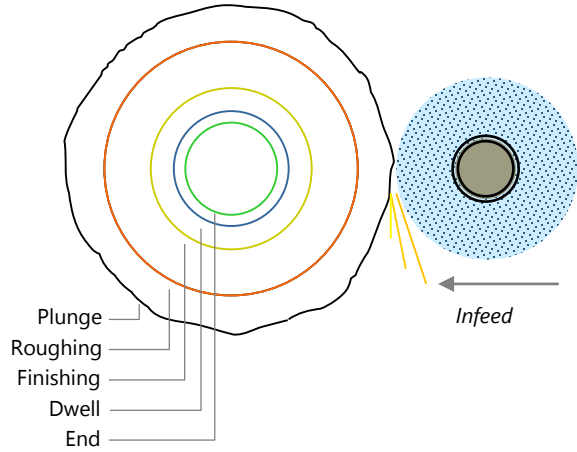
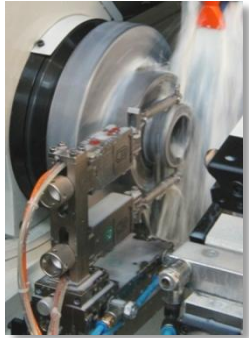

○ Signal to CNC/PLC

CASE x

CASE 1: Traverse time = 0

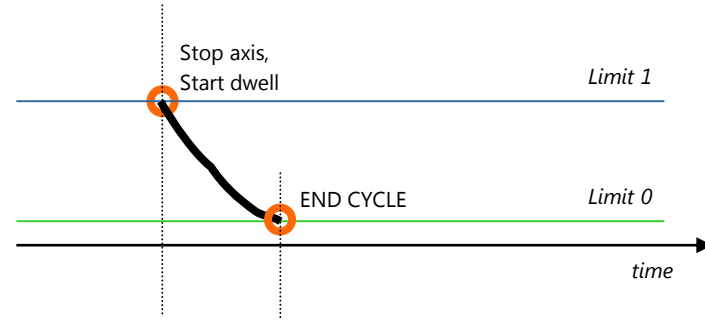

CASE 2: Traverse time ≠ 0

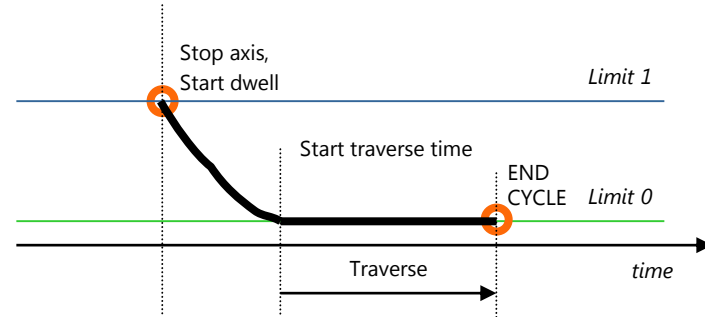

CASE 3: Limit 1 not reached (after dwell timeout the Limit 1 is forced)

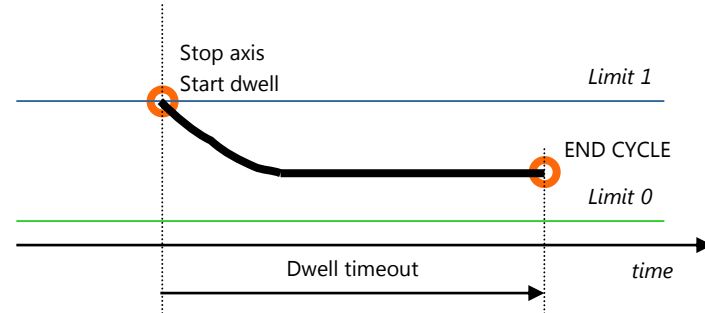

Part Program & Formula

$$D = Kq (Ka G2 + Kb G3 + Kc G4 + Kd G5)$$

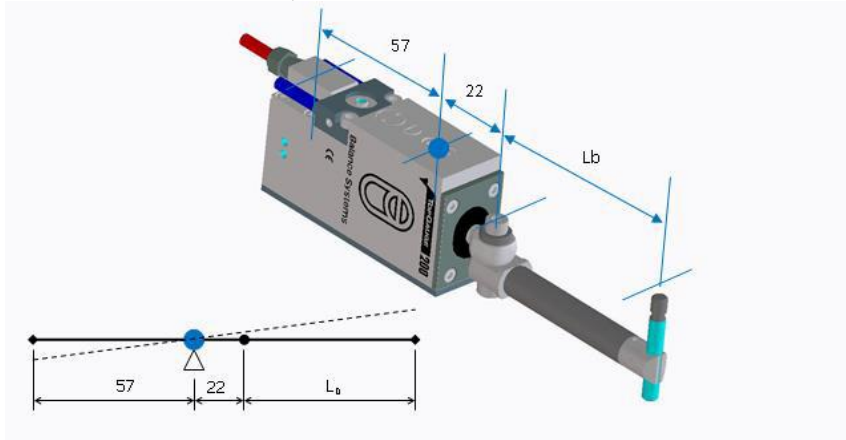
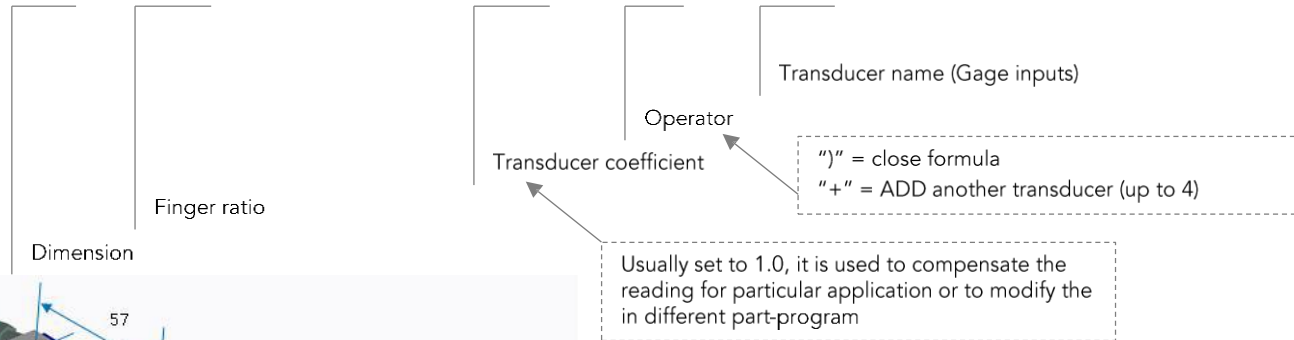

TG200 Fingers ratio	
Finger Length Lb [mm]	Kq
56	1.368
70	1.614
100	2.140
120	2.491

$$Kq = \frac{Lb + 22}{57}$$

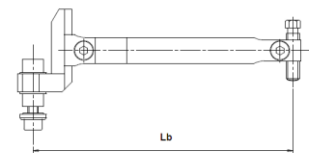

Examples: TG200, Finger 70mm

DIAMETER or THICK FORMULA
 $D = 1.614 (1.0 G2 + 1.0 G3)$

FLAGGING FORMULA
 $D = 1.614 (1.0 G2)$

TAPER FORMULA
 $D = 1.614 (1.0 G2 + 1.0 G3 - 1.0 G4 - 1.0 G5)$



Part position detection (Flagging). 軸向定位與位置探測：

A-透過固定位置探測每件工件端面位置差異，即可參考或修正Z軸向原點位置(被動定位)。

B-透過架設於砂輪側的端面量測，即可得到參考工件Z軸端面探測之更新零點位置(主動定位)。

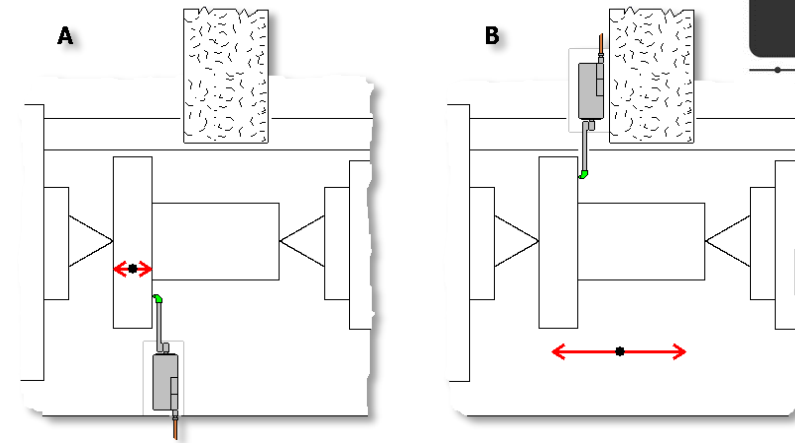

Flagging

Taper correction.

椎度是由砂輪與工件移動值向相互配合的平行度造成，在砂輪進行橫移切削時，則取決於砂輪形狀。此量測透過椎度大徑與小徑的探測，系統計算出角度，以確保於公差範圍內。

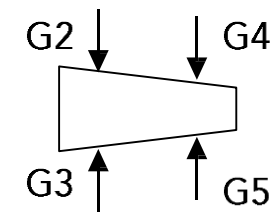
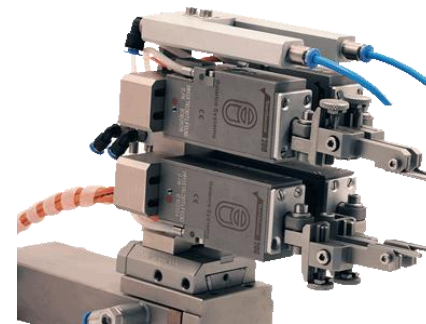



Match grinding.

針對配合件，母件尺寸在線外進行量測確認，系統透過回饋尺寸直接修正外徑最終尺寸零點位置，確保公件對應正確的最終尺寸($D=d$)。

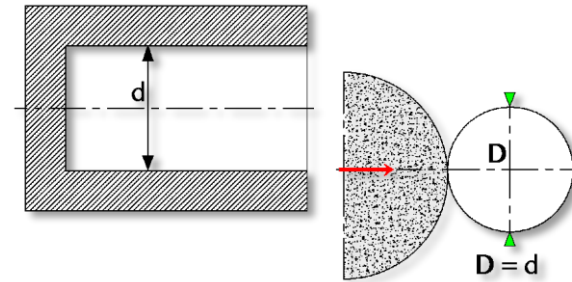

Pre-process 預先量測與研磨起點(厚度)確認.

每一工件均再加工前進行量測，於上料加工前即確認預留研磨量與起始點。

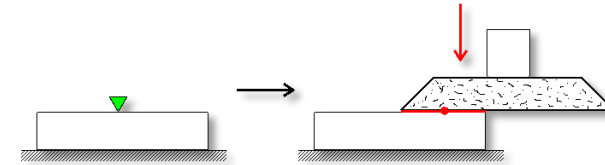

Post-process.

於加工後的機外進行尺寸量測，透過上、下偏差值的預先判讀，得知尺寸偏移趨勢，進行預先補償，得到穩定的批量生產尺寸。
或搭配U+Reporter軟體，記錄成品尺寸。

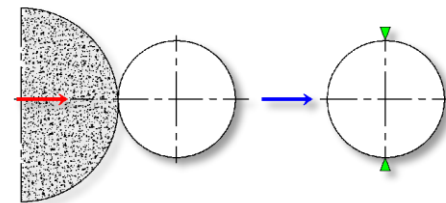

- 用於不連續表面:
 - 半圓柱形
 - 斷續面
 - 無心機械的輸出工件
- 同步訊號源:
 - 透過近接開關觸發
 - 透過尺寸閥值機械觸發
 - 透過遠端接口觸發(Profibus/Profinet)
- 生成的尺寸: 最大尺寸、最小尺寸、平均尺寸、連續尺寸等

WATCH NOW



齒輪外徑量測

Examples

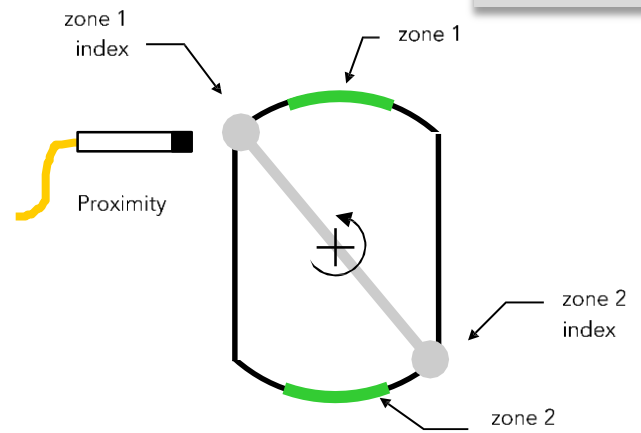

- HW trigger: Proximity
- Zone defined by parameters
- Dimension: Continuous check in green area

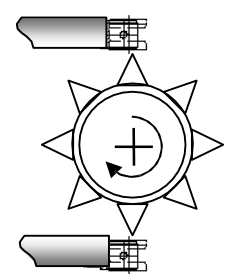

- SW trigger: Parameter RPM
- Zone: 360°
- Dimension: Max

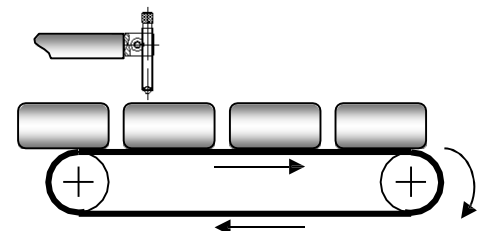

- Mechanical trigger: Dimension threshold
- Dimension: Max

加工中/加工後 圓度檢查

- 砂輪磨耗和不完美平衡的砂輪振動會導致圓度誤差，從而嚴重損害圓柱的品質。它的控制可以避免廢品的產生，它是通過同步量測儀獲得，同步量測儀只需要單支和同步傳感器。

後處理圓度檢查:

- 執行形狀分析以評估每個組件(偏心率與橢圓度等)。
- 當組件形狀超過公差時激活輸出。

自動化搭配:

- 自動化上料時，可以透過圓度檢查，判定工件是否正確安裝置加工機，避免產生偏擺現象。

Formula for finger L=70mm : $Rnd = 1.614 G2$

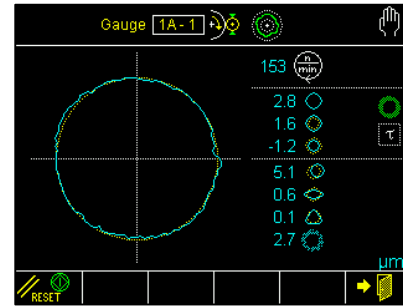

Harmonic	Source of possible cause
0	Correspond to the radius of the component
1	Represents eccentricity, i.e., instrument setup (centering)
2	Ovality of the work-piece or instrument setup (tilting)
3-5	Distortion caused by clamping or manufacturing forces
6-20	Chatter caused by lack of rigidity of the machine tool
20-100	Process effect, tool marks, etc.
> 100	Material effects

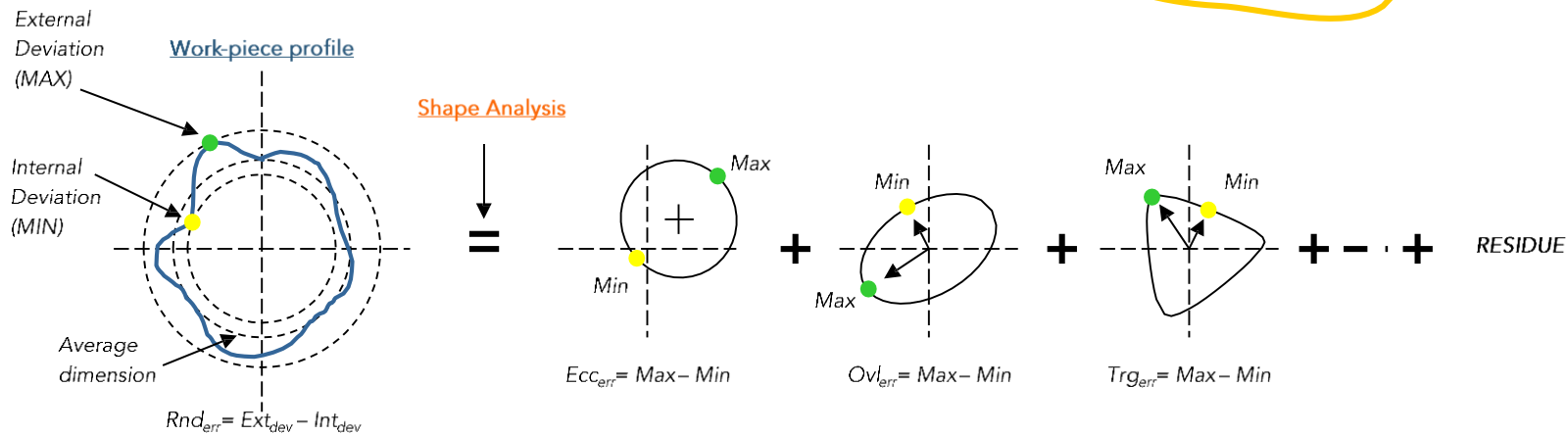
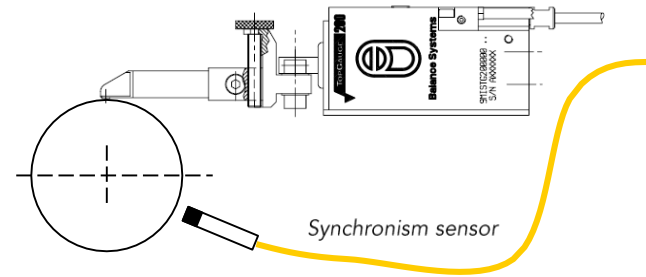

TOP Gauge Absolute (TGA)

絕對式的量測系統，可以快速進行多段尺寸量測，在面對多段差的工件時，不需要重置單個尺寸，快速提升整體效率，且確保工件多段尺寸。

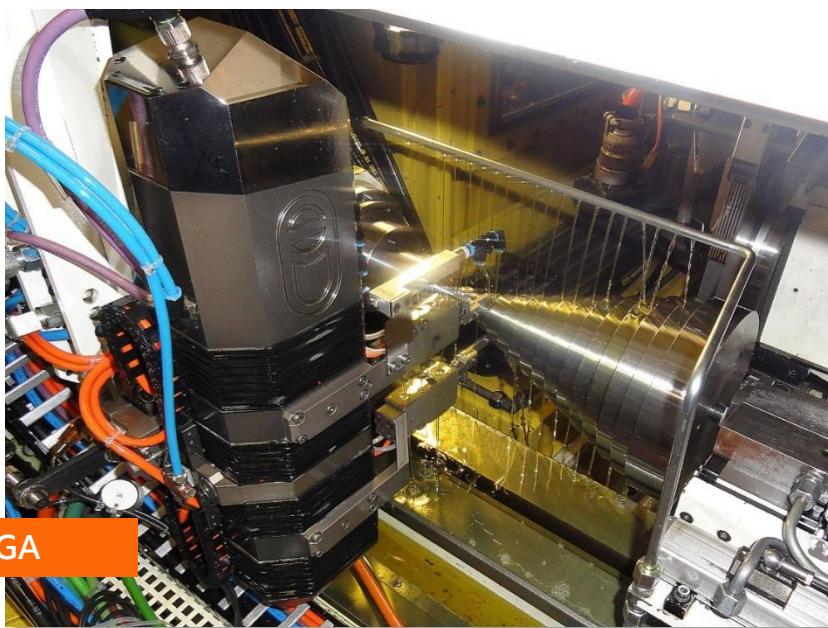
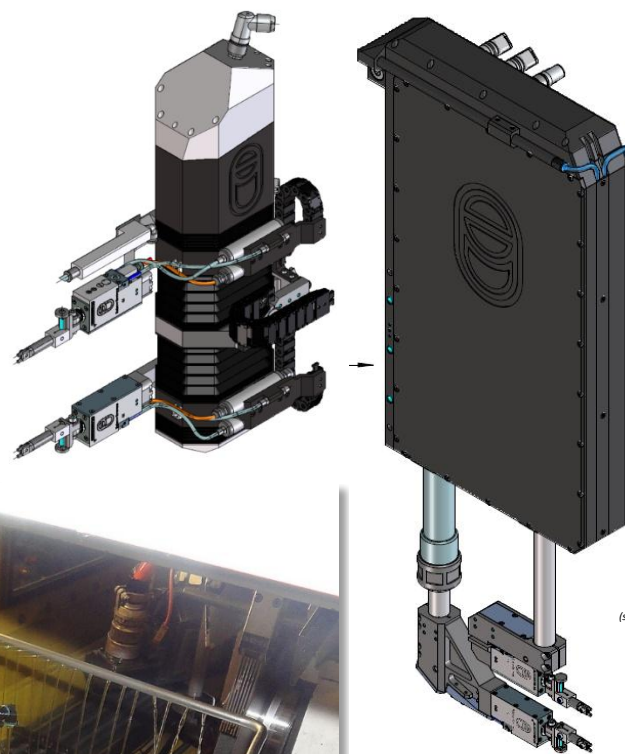

WATCH NOW



TGA

- TGA90
- TGA200
- TGA300
- TGA400
- TGA700

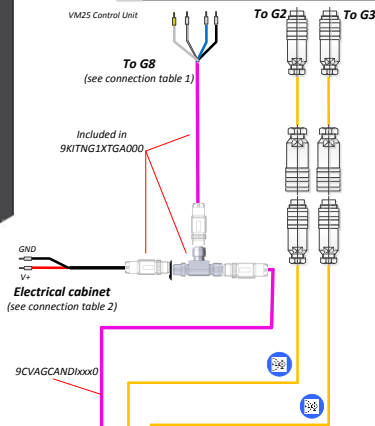
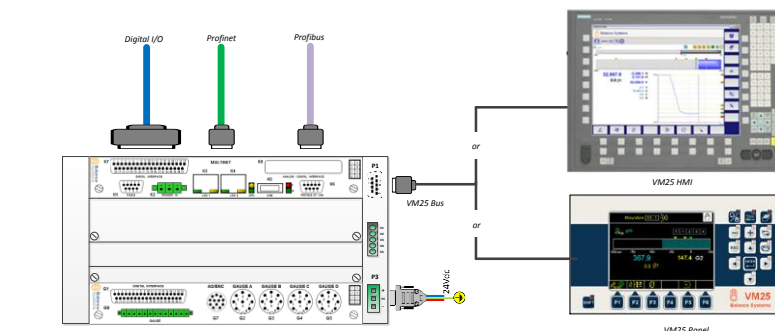

Connection table 1

Connector G8 – I/O
Type Phoenix 13 pin – MC 1,5/13-GF-3,5 THT

PIN	Type	Name	Activation (*)	Description	Wire color connection for TGA application
1	BUS high			BUS high for absolute gauge	White
2	BUS low			BUS low for absolute gauge	Blue
3	BUS ground			BUS ground for absolute gauge	Black
13	Power	PE		Earth	Shield (YELLOW CRIP TERMINAL)

Connection table 2

Female connector – Power supply
Type Binder 5 pin

Welding side view

PIN	Type	Name	Activation (*)	Description
3	Power	GND		Ground
2	Power	+24 Vdc		+24 Vdc power supply

TOP GAUGE ABSOLUTE	TGA90	TGA200	TGA300	TGA400	TGA700
MEASUREMENT RANGE [mm]	90	200	300	400	700
MEASURABLE Ø MIN [mm]	4	10	10	50	200
MEASURABLE Ø MAX [mm]	120	250	450	550	1000
REPEATABILITY 2σ [µm]	1	1,5	2	2,5	4
WEIGHT [kg]	7,5	12	25	40	80
GAUGING SURFACES	Continuous and Interrupted				
OPERATING TEMPERATURE [°C]	0°.. 50°				
WATERPROOFNESS (IEC 6059)	IP68				
ELECTRIC SUPPLY [V-A]	24 Vdc ±20% - 1A				

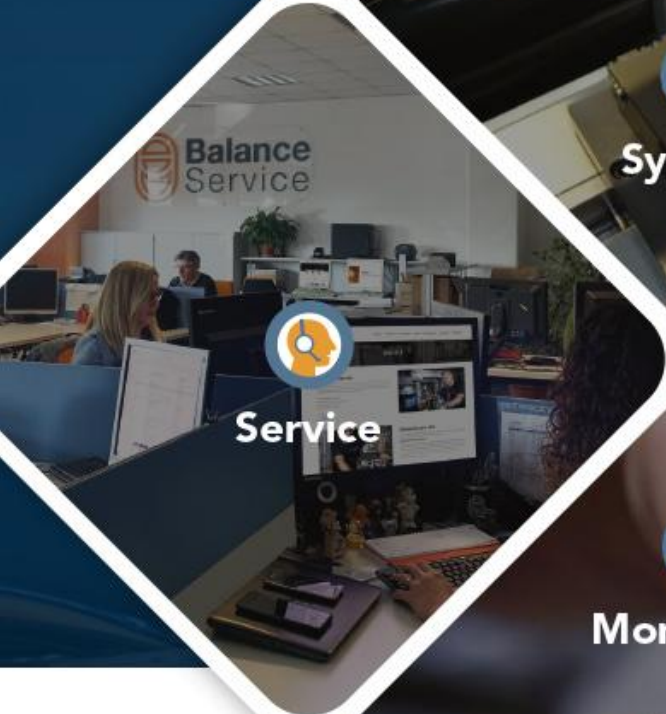
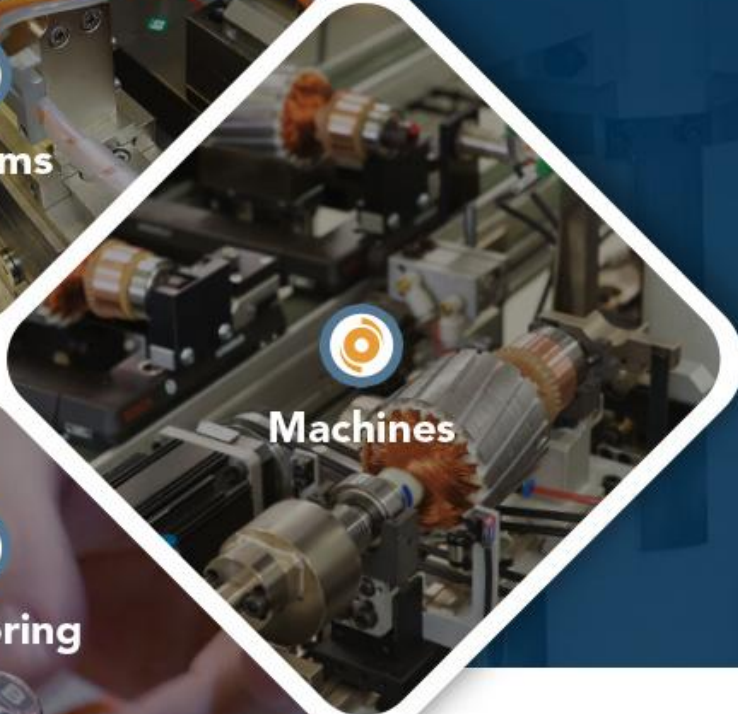

CASE STUDY

VM25三合一舊機改裝:

- 新增砂輪動平衡
- 新增音頻防撞
- 新增外徑量測

WATCH
NOW

舊機改裝

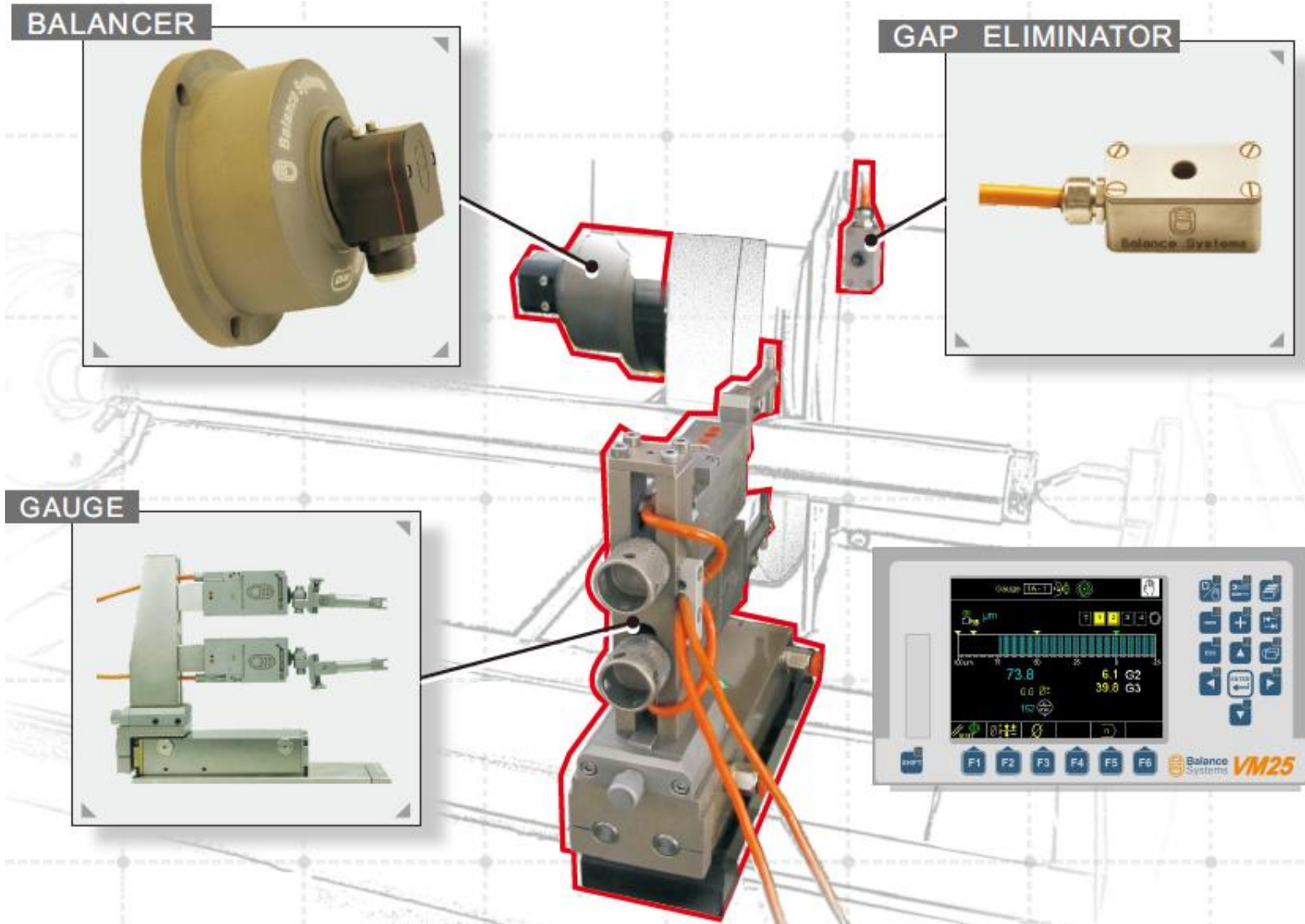

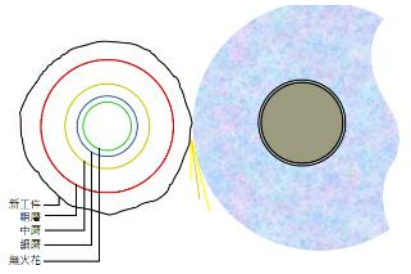
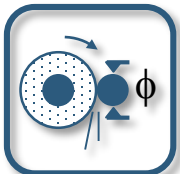

WATCH NOW



Thickness



ID

Post-gauge



ID

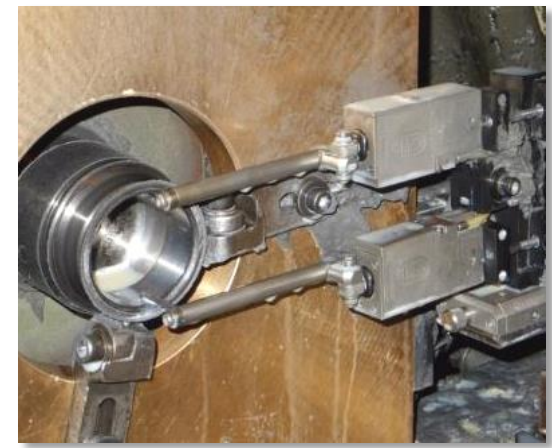

Thickness

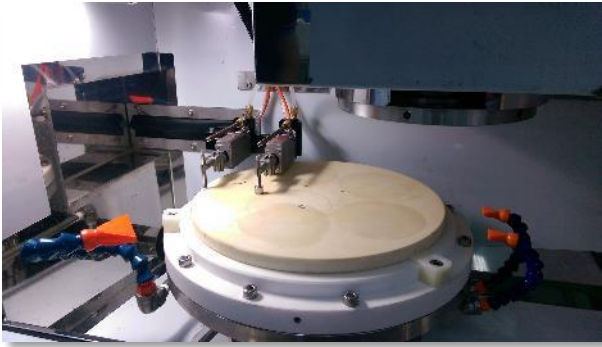

OD Plain & Flagging



OD Interrupted

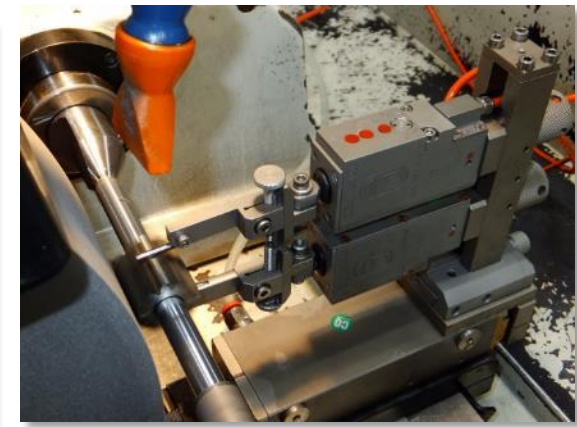

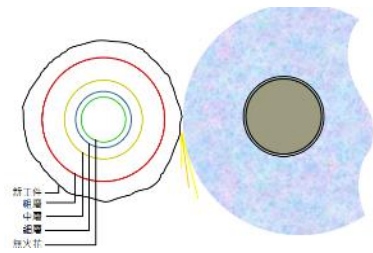
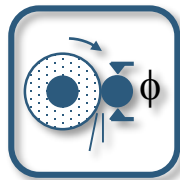

WATCH NOW

Centerless

刀把

OD Quick re-tooling & Anti-Crash

Centerless

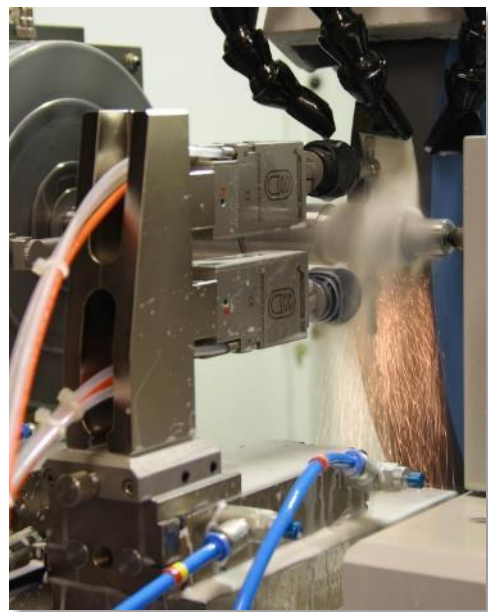

Multi-Gauge- Gear Pump



Tool Holder



Post-gauge Thickness





Systems

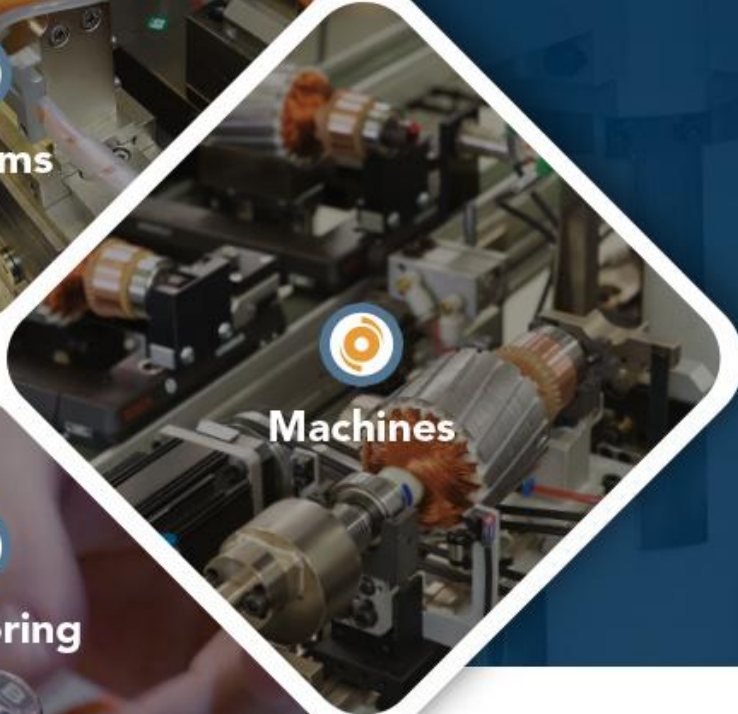

Machines

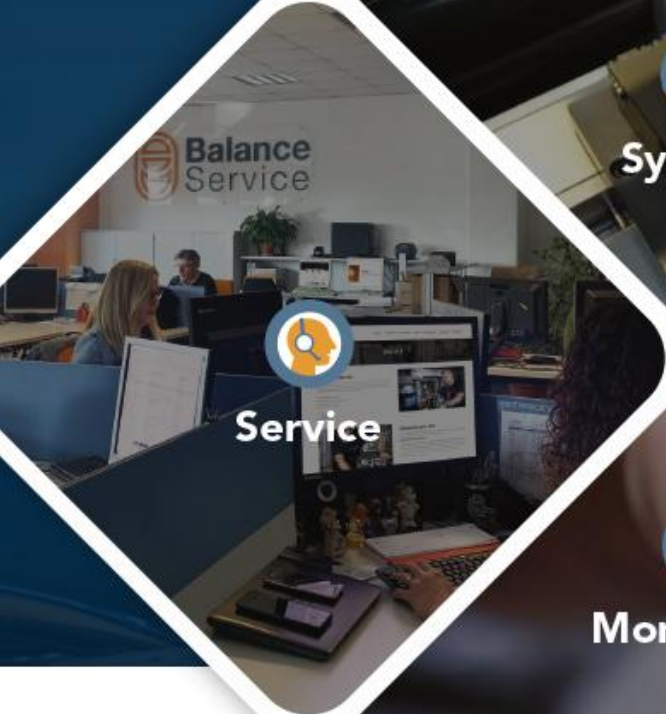

Service



Monitoring

**POST-GAUGE x AUTOMATION x
SOFTWARE INTEGRATIONS**

線上品檢自動化之串聯_機外量測



- 透過各站連線，以自動化品管控制。
- **品管監控避免連續不良品的產生。**
- 降低人力。
- 自動生成報表，提供生產數據。
- 客製軟體開發

加工機
(控制器)

移載
機械手

量測
品檢站

軟體

機台監控與資料收集



分析報表



以量測標的分類

BS機外量測

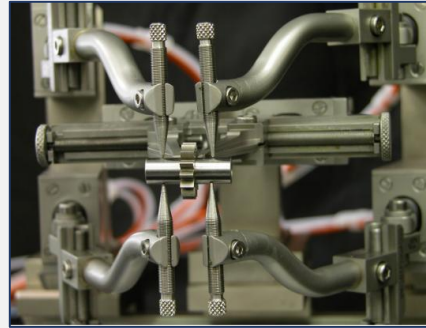

針對工件特定尺寸量測要求

客製專屬需求
速度快、精度高
成本優勢

REN機外量測



針對多樣性工件尺寸量測要求

適用於複雜形狀
可針對多種不同工件量測應用
簡單夾具要求





VM25_GA-精密量測系統

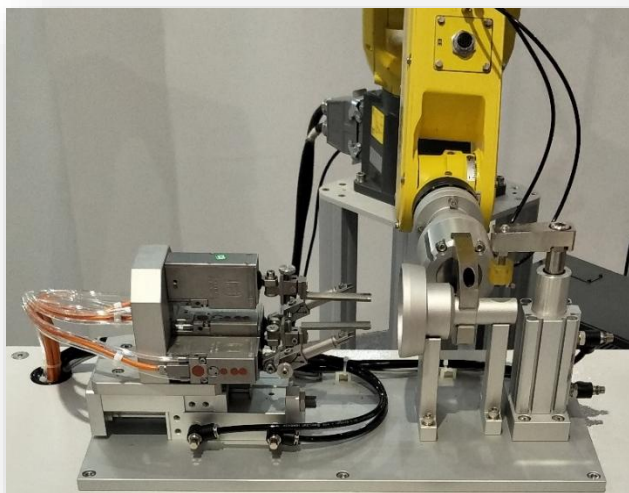

- 量測系統支援多測頭，可單工件多點量測。
- 機內 / 外量測可進回尺寸回饋補償，達到工件品質穩定。
- 客製量測軟體可記錄每個尺寸，可上傳工廠管理系統或產出檢驗報告。
- 量測探頭IP67，防護性佳。
- 測頭精度0.1 μ m。

WATCH NOW



VM25GA

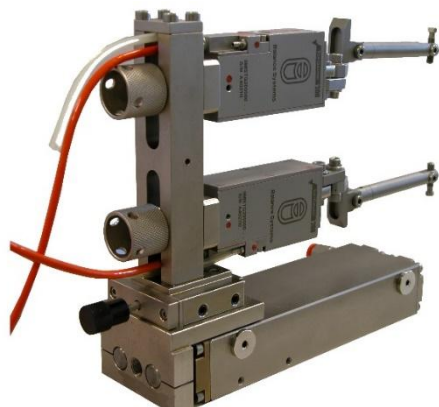

RENISHAW Equator 300/500 – 多功能比對儀

apply innovation

Equator獨特創新的檢驗技術是透過3D掃描方式將加工生產件與標準工件進行比對量測，可擷取的數以千計的點資料，使量測結果更加精確，也可展現**高效率的形狀量測**。



WATCH NOW



Equator

手機殼量測案例

線上品檢自動化之串聯

- **PC機聯網客製軟體:**
 - 結合工單導入，自動程式切換，公差設定，機械手程式選擇，**量測數據資料庫建立**，**續研磨控制**等，核心主導控制單元。
- **TGA量測系統:**
 - 進行多段工件量測，進行不同位置段差量測，補償回饋。
- **機械手臂:**
 - 透過6軸關節手臂，靈活特性閃避機構干涉，夾持量測儀器進行工件尺寸量測。

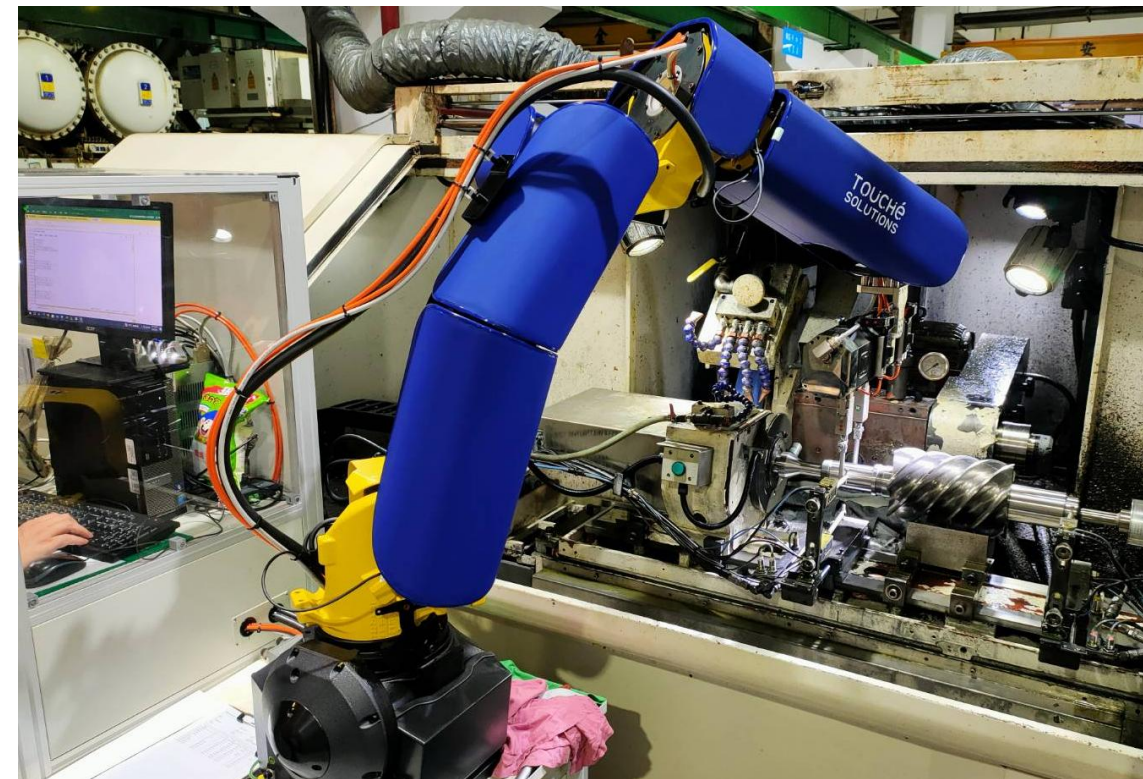

Ver: 1.0.4-6670art19

Fanuc: Stop 手動準備中 Robot: Start 量測開始 Alarm:

Step.1 使用者代碼 11203666 工作站 GN-04 件號 DS41母轉子

Step.2 製造號碼 2522020080C2300002 工單號碼 20230619110813 件號 配對表: 1

Step.3 自動加工 手動量測

選擇加工件或是加工方式

Step.4 量測資料 目前量測 0 次 手動量測啟動

Sort	參數名稱	單位	規格下限	製制下限	期望值	管制上限	規格上限	原值	新值	補正值	機台移動	手動全通
1	GN_G排氣機軸承外徑(2)	mm	50.0000	50.0009	50.0000	50.0090	50.0100	0.0000	0.0000	0.0000	-900	量測
2	GN_F排氣機軸承外徑	mm	55.0100	55.0114	55.0000	55.0235	55.0250	0.0000	0.0000	0.0000	-900	量測
3	GN_E排氣機軸承外徑	mm	69.9550	69.9564	70.0000	69.9685	69.9700	0.0000	0.0000	0.0000	-900	量測
4	GN_C排氣機軸承外徑	mm	69.9550	69.9564	70.0000	69.9685	69.9700	0.0000	0.0000	0.0000	-900	量測
5	GN_D排氣機軸承外徑	mm	55.0100	55.0114	55.0000	55.0235	55.0250	0.0000	0.0000	0.0000	-900	量測
6	GN_H排氣機轉部外徑	mm	50.0000	50.0009	50.0000	50.0090	50.0100	0.0000	0.0000	0.0000	-900	量測

Step.5 上傳量測資料至CIMES 上傳量測資料 放棄量測資料

WATCH NOW



TGA+Robot

金屬加工 自動化案例

WATCH
NOW



ID&Robot



OD&U+RG



機外量測站

WATCH NOW

- ▶ 雷射&U+RG
- ▶ 無心
- ▶ 多點量測2

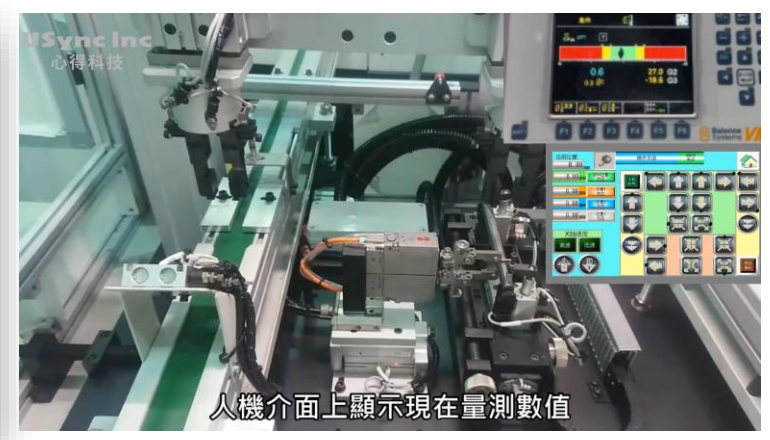
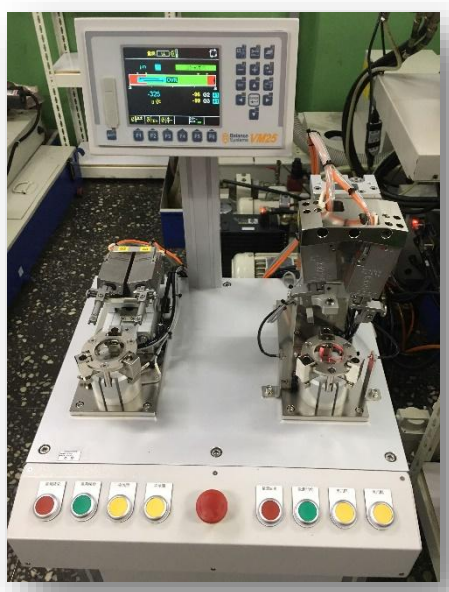



O型環自動收納盒

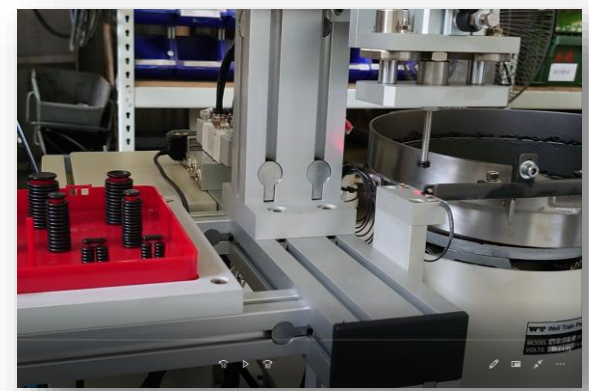

O型環製程自動化



零組件自動組裝

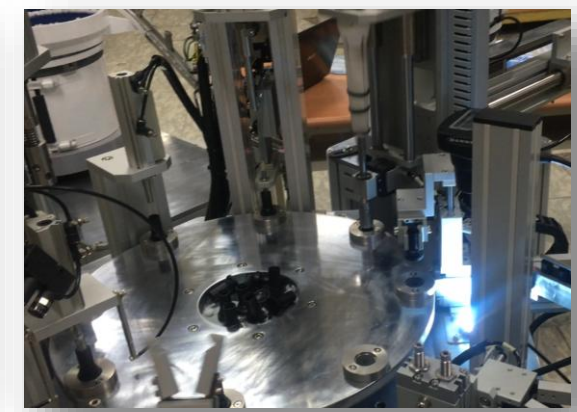

3D+2D亂數取料

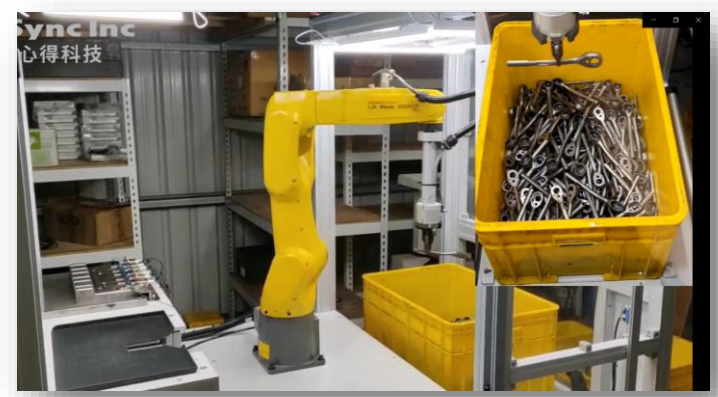

銑床+置具盤



門型自動化



- VM25這套系統最初設計是使用在什麼加工機上面？車床？銑床？“磨床”？

磨床

- TGA量測系統是比對式還是”絕對式”的系統？

絕對式

- 在自動化產線上，若加工”機內”部無法安裝測頭進行量測，要如何確保工件尺寸在公差內，我們可以使用什麼方式去做尺寸量測補償？

機外量測





Process control and monitoring systems for machine tools and
balancing machines for rotating components for over 50 years

Thank you for your attention

Balance Systems S.r.l. (Italy)

Via Roberto Ruffilli, 8/10 - 20060
Pessano con Bornago (Milan) - Italy
Ph. +39 02 9504955
Fax +39 02 9504977
info@balancesystems.it

Balance Systems GmbH (Germany)

Albert-Einstein-Strasse 2
70806 Kornwestheim - Germany
Ph. +49 7154 8160471

Kelterstrasse 3,
75236 Kämpfelbach - Germany
Ph. +49 7231 426746

info@balancesystems.de

Balance Systems France

Zone d'Activités des Forboeuf
5 Rue des Frères Lumière
95280 Jouy le Moutier, France
Ph. +33 1 34464972
Fax +33 1 34413130
info@balancesystems.fr

Balance Systems Corp (U.S.A.)

28003 Center Oaks Ct #107 Wixom, MI 48393
U.S.A.
Ph. +1 248 3083636
Fax +1 248 4935920
info@balancesystems.com