



LIY CHENG
Liy cheng Precision Co., Ltd.

HIGH PRECISION

High Precision Hardened Tooling Design to Manufacturing

STATE OF THE ART, HIGH PRECISION TOOL
MANUFACTURING SERVICE.

先進的技術、高精度製造加工服務

高硬度精密模具
設計開發 High Precision
High Quality
High Efficiency

B U S I N E S S

關於我們

About Us

立承創立2012年

秉持著10多年的精密加工製造經驗。
專營各種CNC高硬度模具及二~五軸精密零件加工，
透過先進的技術、精良的設備及不斷的製程改善，
我們致力於提供客製化產品 & 服務，並透過不斷的進步與創新，
立承始終為模具製造業的領導標竿。

Liy Cheng is established in 2012,
a company with high expertise in various high precision hardened tooling,
from single to complex machining component
manufacturer with over 10 years' experience.
Offering a blend of technology and craftsmanship,
we are a one-stop shop with design,
proto and production tooling, metrology, production, continuous improvement.

- *High Precision Hardened Tooling Design to Manufacturing*
高硬度精密模具 (塑膠模、沖壓模、PM模及MIM模具) 設計開發
- *Free Form Machining*
高精度曲面模仁加工
- *Custom Precision Component Machining*
客製精密零件加工
- *5-axis CNC Machining*
五軸精密模具/零件加工
- *Tungsten Carbide Machining*
鎢鋼加工



高品質 / 高效率 / 高精度

立承願景 Our Vision

01

為我們最尊敬的客戶提供最佳的解決方案
Offer the best **solution** to our valued customer.

02

確認、實施 最新且最有效率的加工技術
Identify and implement the newest and most effective **technology** available.

03

提供員工完善的教育訓練與成長機會
Provide opportunities for growth and enhance **training** for our staff.



Part/01



設備與環境

Facility

(equipment and peripheral)

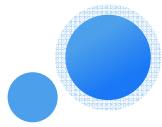

Facility – Equipment and peripheral 設備與環境



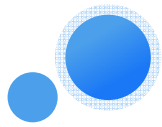

Facility – Equipment and peripheral 設備與環境



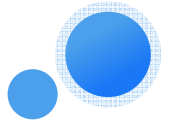

Facility – Equipment and peripheral 設備與環境



Equipment – CNC Milling Machine



YASDA YBM Vi40V3

- 5 axis milling machine
- Max RPM 24000
- Table working surface
Ø500*H350 / 200 kg
- Accuracy ± 0.002



YASDA YMC 430V2+RT10

- 5 axis milling machine
- Max RPM 40000
- Table working surface
Ø250*H170 / 15 kg
- Accuracy ± 0.001



NUMEN Delta 8

- 3 axis milling machine
- Max RPM 20000
- Table working surface
950x660mm / 600 kg
- Accuracy ± 0.003



NUMEN Delta 6

- 3 axis milling machine
- Max RPM 36000
- Table working surface
600x550mm / 300 kg
- Accuracy ± 0.003

Equipment – CNC Milling Machine



YASDA YMC 650

- 4 axis milling machine
- Max RPM 40000
- Table working surface 700x500mm / 200 kg
- Accuracy ± 0.001



YASDA YBM 640V3

- 3~4 axis milling machine
- Max RPM 24000
- Table working surface 700x450mm / 300 kg
- Accuracy ± 0.001



YASDA YMC 430

- 3 axis milling machine
- Max RPM 40000
- Table working surface 600x350mm / 100 kg
- Accuracy ± 0.001

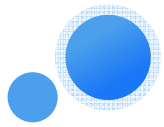

Equipment – CNC EDM Machine



SY-CNC 4050T

- CNC series EDM Drill
- Table working surface 800x500mm / 800 kg
- Accuracy ± 0.005



AgieCharmilles CUT P 350

- High precision cutting machine
- Table working surface 800x550mm / 750 kg
- Accuracy ± 0.002



MITSUBISHI MV1200R INTEGRATED

- High precision cutting machine
- Table working surface 810x700mm / 800 kg
- Accuracy ± 0.002



MITSUBISHI MV2400R INTEGRATED

- High precision cutting machine
- Table working surface 1050x820mm / 1500 kg
- Accuracy ± 0.002

Equipment – CNC EDM Machine



AgieCharmilles CUT P 550

- High precision cutting machine
- Table working surface
550*350mm / 1500 kg
- Accuracy ± 0.002

Part/02

製作流程

ENGINEERING

+ Tooling Development Process

ENGINEERING+ Tooling Development Process

設計、模具開發流程

Tool 3D Model design to the Mold flow analysis.
模具3D設計並進行模流分析

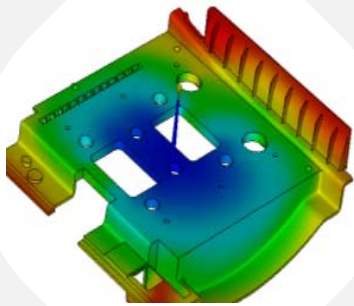

CAD Design from the draft to the complete 3D Model.
從草圖或客戶提供之成品到完整的3D模型建立

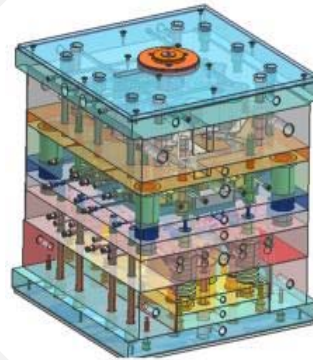

CAM Simulation to calculate correct Radius Material removal before Finishing.
在正式加工前進行加工程式模擬

Prototype Tool Built to Complete CMM Inspection
成品三次元檢驗

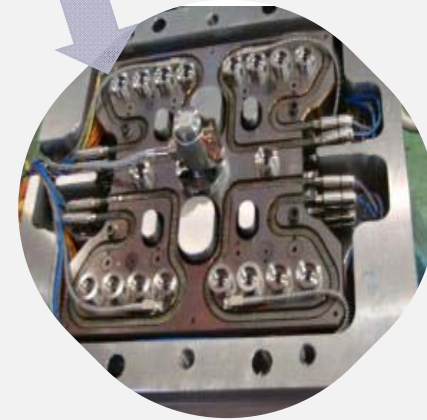

Mass Production Tool (Follow-up and service)
生產、售後追蹤與服務

High Precision
High Quality
High Efficiency

Part/03

加工產品

Milling Sample



Milling Sample –Plastic Injection Tool

塑膠射出模具(高爾夫球模具)

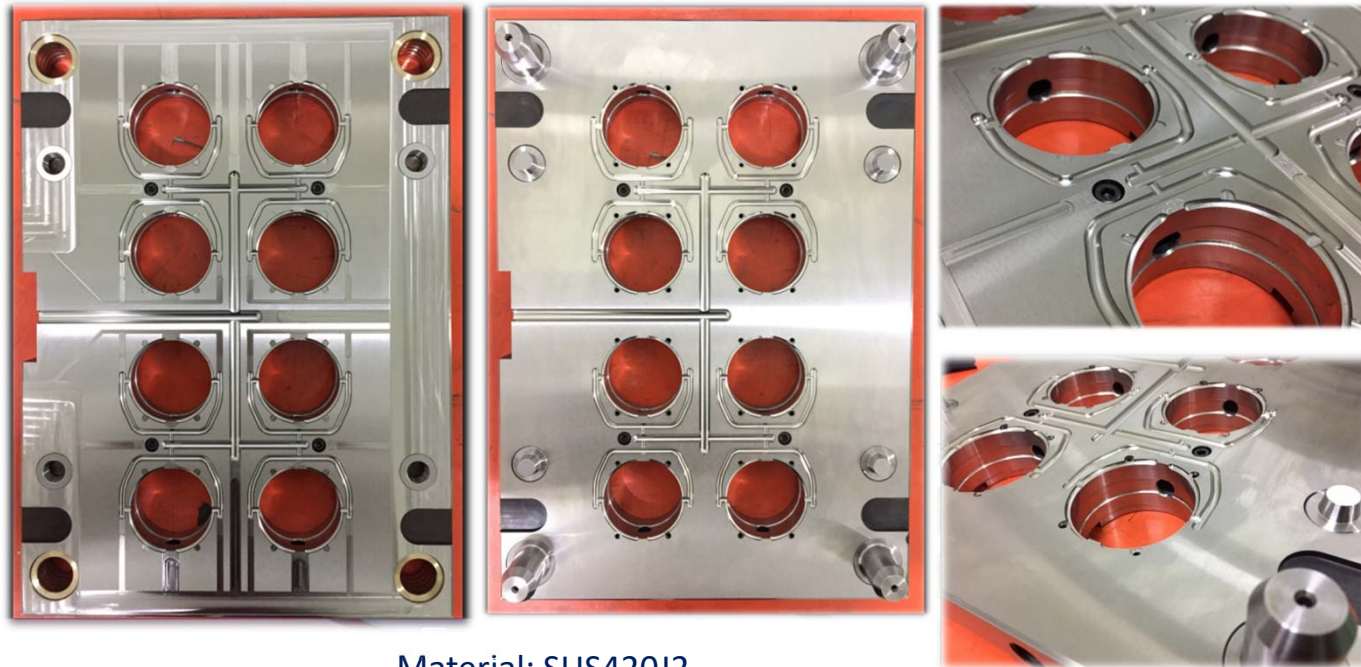

Material: SUS420J2
Hardness: HRC48~54



Material: SUS420J2
Hardness: HRC38~42

Milling Sample – Plastic Injection Tool
塑膠射出模具(車燈模仁)

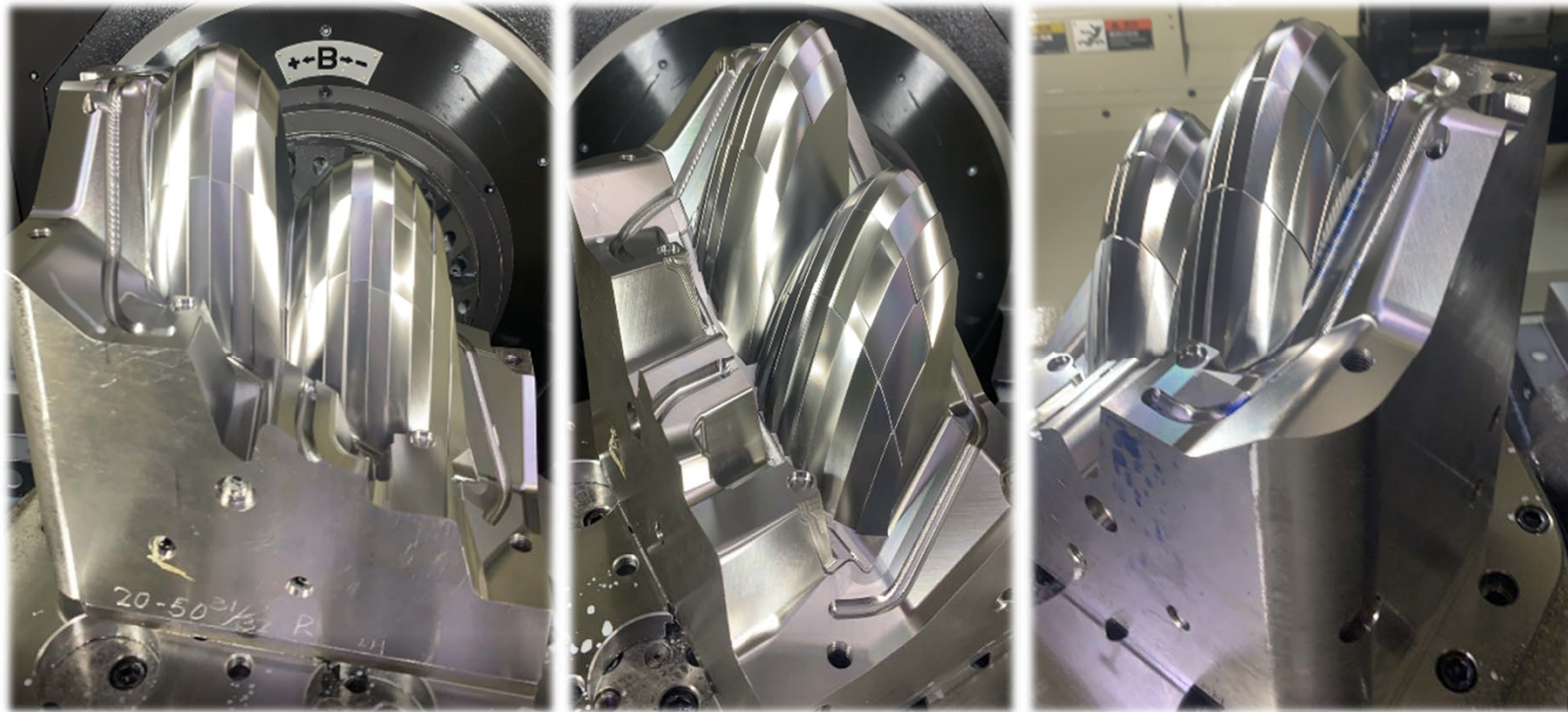

Milling Sample



精密線切割
Wire EDM precision machining



高硬度直雕
Direct Machining on Pre-hardened Material

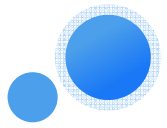

Milling Sample



鎢鋼直雕
Direct Machining on Tungsten Steel



五軸加工
5-Axis Precision
Machining



光學模仁
Optical
Lens

Part/04

品質保證
量測儀器

Quality Assurance
QC Equipment

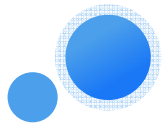

Quality Assurance – QC Equipment

量測設備



**Brown & Sharpe
Global Performance**

- Touch Probe CMM with Scanning Capability
- $E=1.5 + L/333 \mu\text{m}$ $P=1.6 \mu\text{m}$



Leitz Reference HP

- Touch Probe CMM with Scanning Capability
- $E=0.7 + L/400 \mu\text{m}$ $P=0.45 \mu\text{m}$

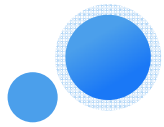

Quality Assurance – QC Equipment

量測設備



Surface Texture
Measuring Instruments



Digital Microscope



Renishaw OMP400
Touch Probe On-Machine
Inspection



TOLTEC Contour
Profiler On-Machine
Inspection



High Gauge



60X Microscope



Pistol Grip Bore Gauge

- Pin Gauge
- Ring Gauge
- Caliper
- Micrometer

Case Study

(High Precision Tool Machining)

Mirror Finish directly from CNC 5 Axis milling for 0.005mm of freeform error.
使用五軸鏡面加工
曲面精度誤差0.005mm

Surface Result

Measured point	Roughness Ra (μm)
Pick dir. (Start point)	0.016
Pick dir. (End point)	0.018
Feed dir.	0.014

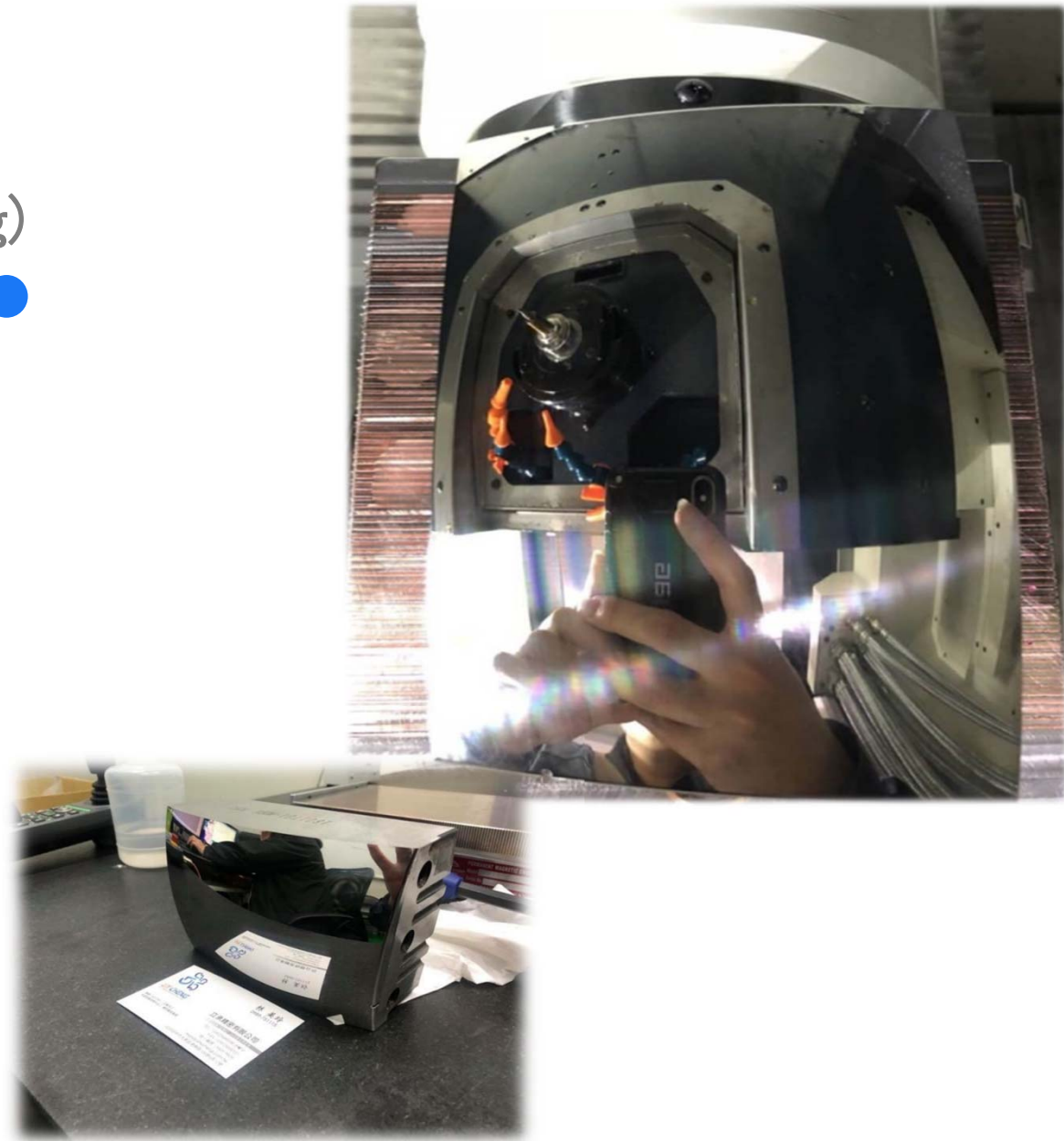



Part/05



研發與創新
R&D and Innovation

Metal 3D Printing – Additive Manufacturing

金屬3D列印

公司預計今年7月導入「金屬3D列印技術」，又稱積層製造，與傳統的「減法式製造」不同在於積層製造技術採用「加法式製造」，即使用者以電腦繪製零件的設計圖或掃描現有物件，再以積層製造設備把原材料層層堆疊形成三維物體，可彌補傳統減法製造工藝無法實現的複雜形狀之金屬成品的製造。

螺旋水路澆口套冷卻效果案例(手機充電接口)

利用金屬3D列印技術，可以在澆口套內部設置螺旋水路，以縮短主流道的冷卻時間。(可以針對主流道部位，設定與模具其他部位不同的控制溫度)

成型週期減少60%

使用前37sec >>>>>> 使用後15sec

冷卻時間減少80%

使用前25sec >>>>>> 使用後5sec



螺旋水路澆口套

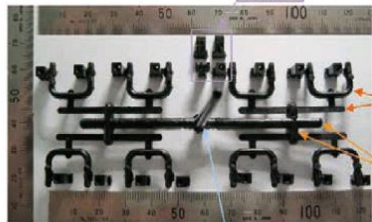

成品
總厚度: 2.0
澆口部: 0.2

20°
A = $\Phi 2.0$
A = $\Phi 3.0$

Sprue L=38.0
 $\Phi 2.5 \times 2'$

產品名稱	手機充電接口	16穴總重	1.3008g
產品尺寸	3.5×3.8×7.5mm	澆口重量	2.56g
單件重量	0.0813g	材質	PET



模具

模具溫度控制機

專用小型溫控裝置

LIY CHENG
Liy cheng Precision Co., Ltd.

金屬3D列印

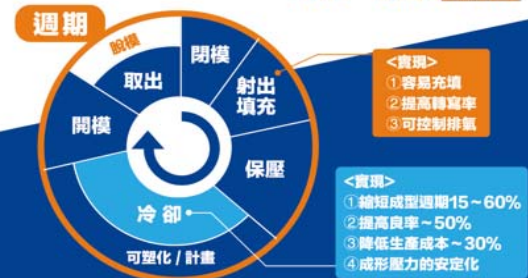

Printing Sample – 3D列印樣品



Material: 透氣鋼breathable steel
Hardness: HRC35~40



Material: M789(Corrax)
Hardness: HRC48~50

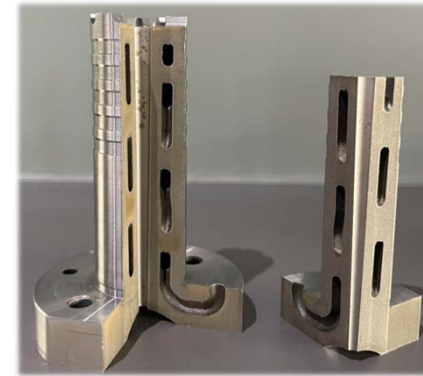
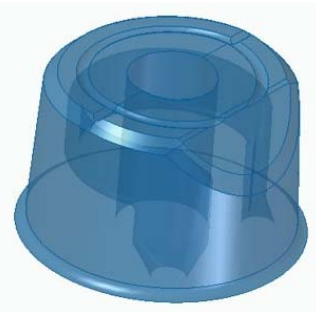

Material: SUS420J2
Hardness: HRC50±2



Material: SUS420J2
Hardness: HRC50±2



Material: 1.2709
Hardness: HRC50±2

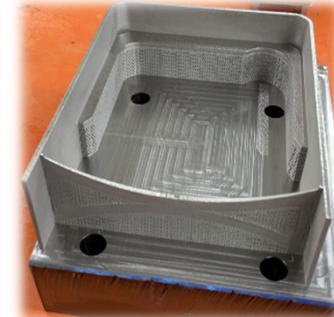
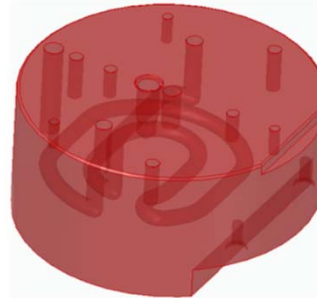

Material: TC4 鈦合金

主題一 精密智慧製造



(一)精密加工要素

- 1.機械的穩定性.....主軸熱深長，機器熱變位
- 2.穩定的環境.....恆溫 20 ± 0.5 度、恆濕 $50\%RH\pm 10\%$
- 3.優秀的人才
- 4.打破砂鍋問到底的精神(不斷求證)

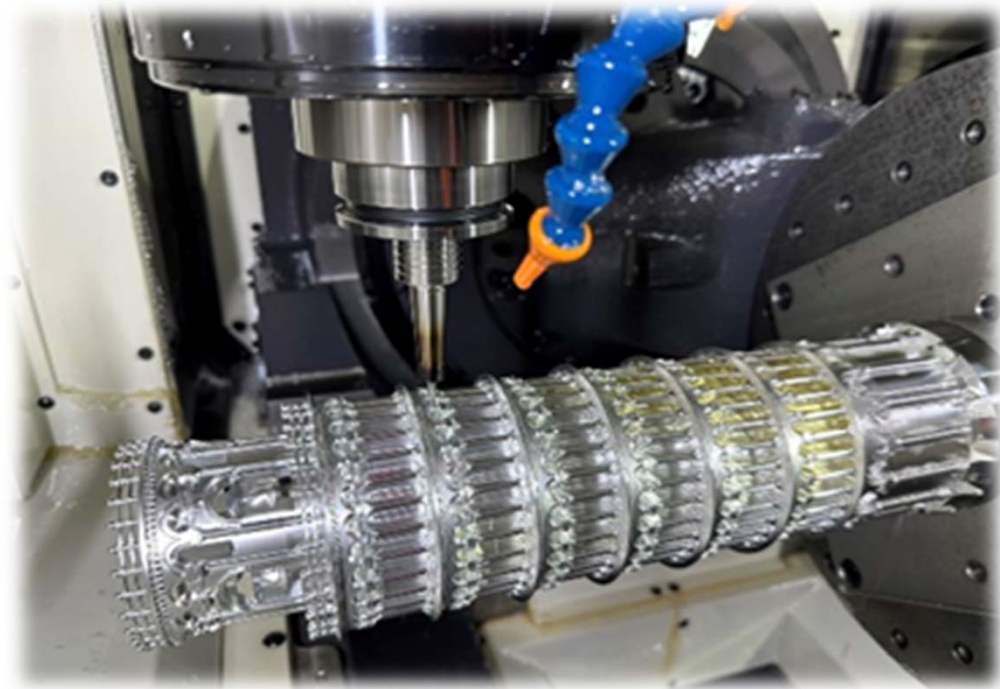

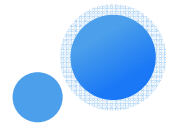

(二) 模具如何做得準確?

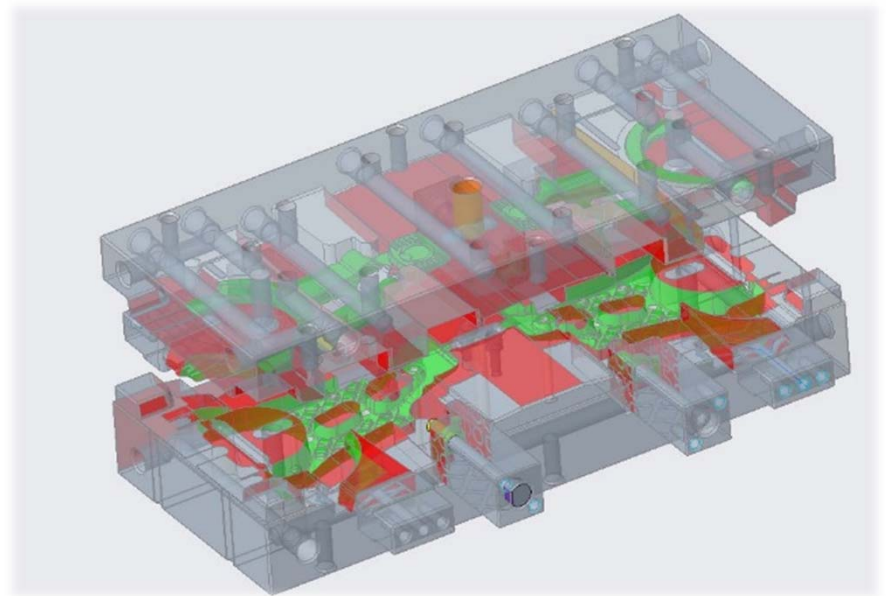
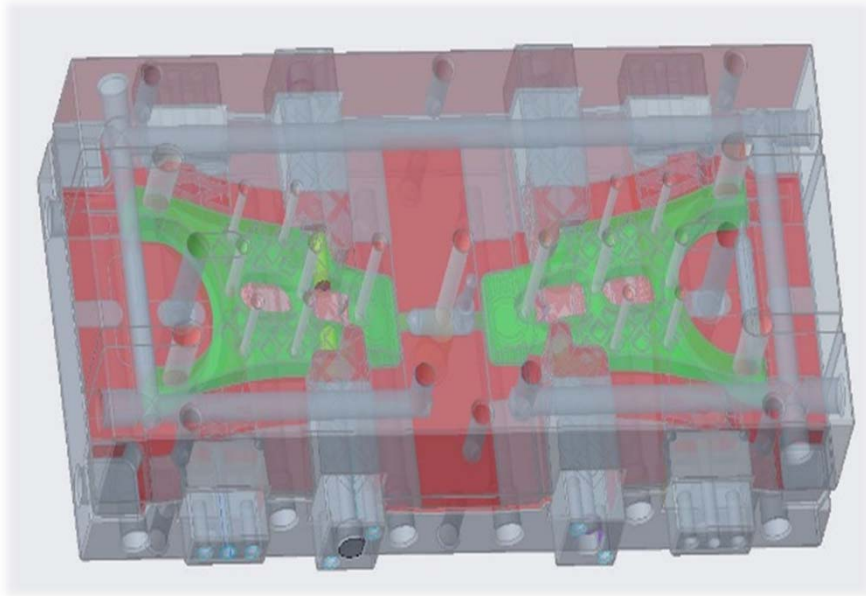

以往的做法

1. 工程師多年經驗補正
2. 模具廠鉗工合模



3. 下機儀器量測後補正

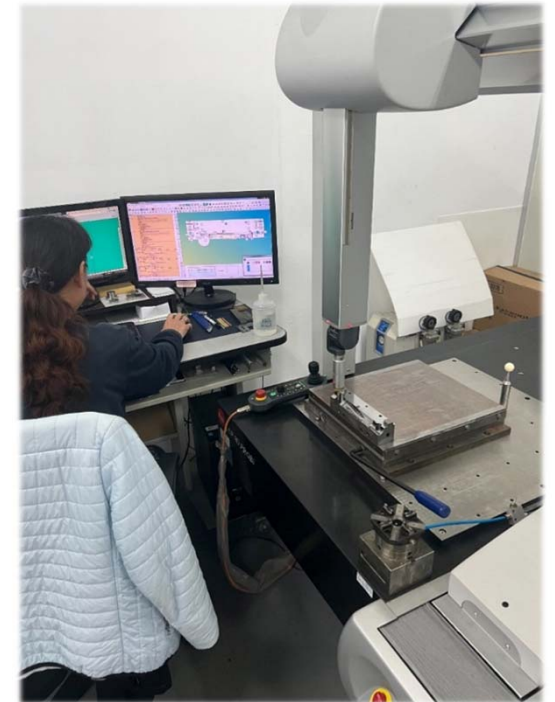

產生問題點

- 1.無正確的數據，且人才不易培養
- 2.多模數無法模仁交換，模仁替換麻煩

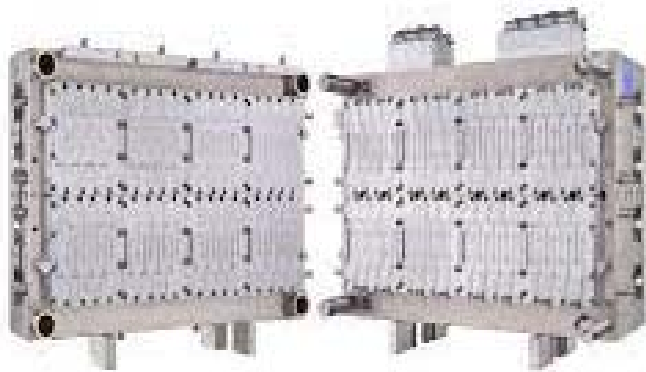

- 3.量測數據是否可靠?

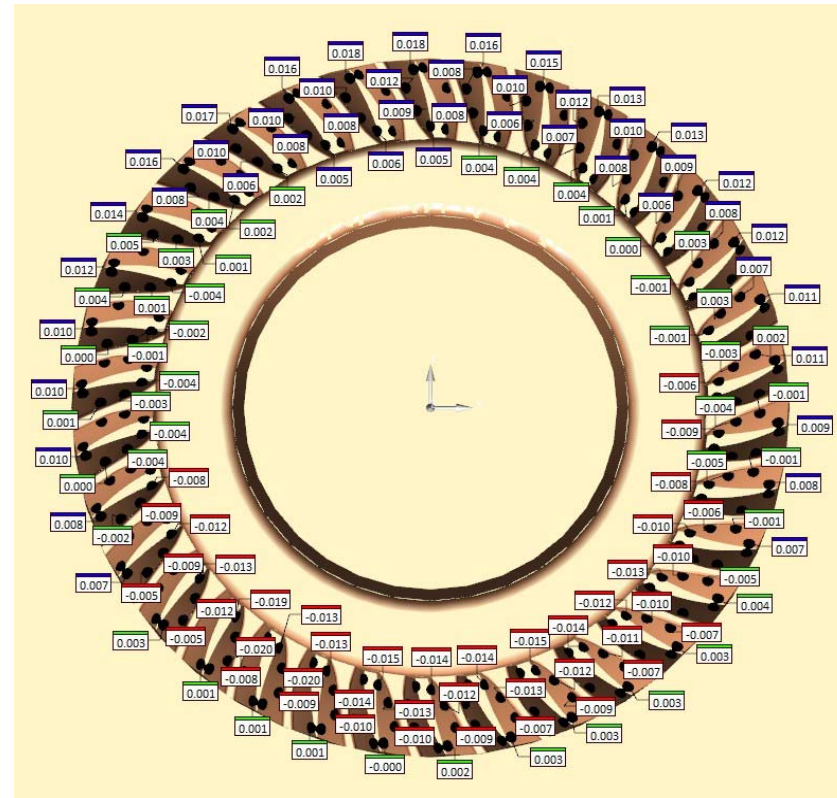

(三)立承智慧製造導入與分享



(三)立承智慧製造導入與分享

1.THERMO-viz 溫度監控系統: 機械周邊環境及切削液溫度計錄監控。

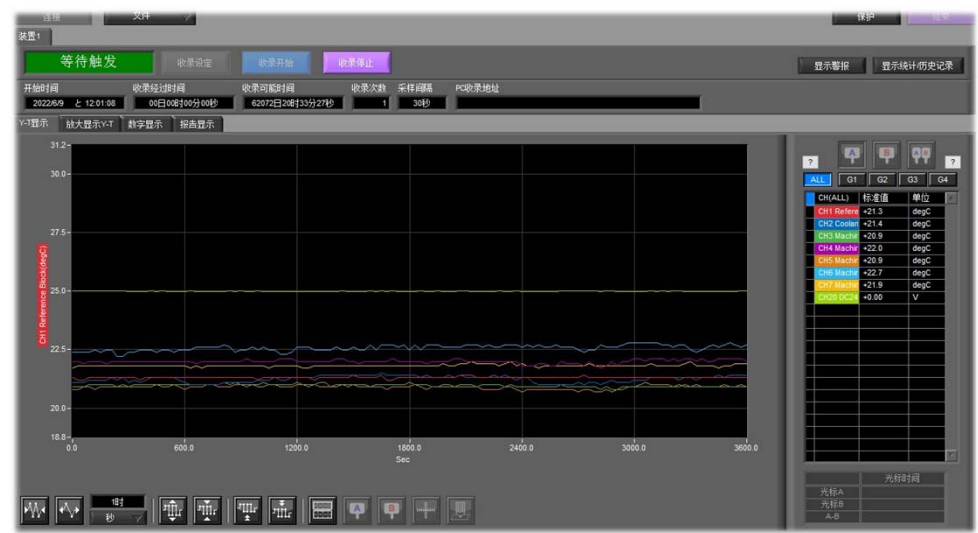

CH 1	CH 2	CH 3	CH 4	CH 5
+ 21.2	+ 21.0	+ 20.6	+ 20.7	+ 21.1
degC	degC	degC	degC	degC
CH 6	CH 7	CH 8	CH 9	CH 10
+ 20.4	+ 21.0	Off	Off	Off
degC	degC	-	-	-

(三)立承智慧製造導入與分享

2. Big Dyna Line 刀具測定儀：因應高精度模具加工需求, 刀具的直徑及輪廓度的尺寸非常重要, 所以公司導入 Dyna Line 軟硬體設備檢測刀具尺寸, 並做資料管理, 避免因為刀具尺寸誤差造成重工, 導致不必要的工時浪費。



(三)立承智慧製造導入與分享

3.RENISHAW OMP-400 及 AEPRO軟體應用:除尋工件座標及簡易幾何量測外，複雜曲面工件加工完成後，在機台上做精度確認，避免下機台後由CMM判定NG造成重工。

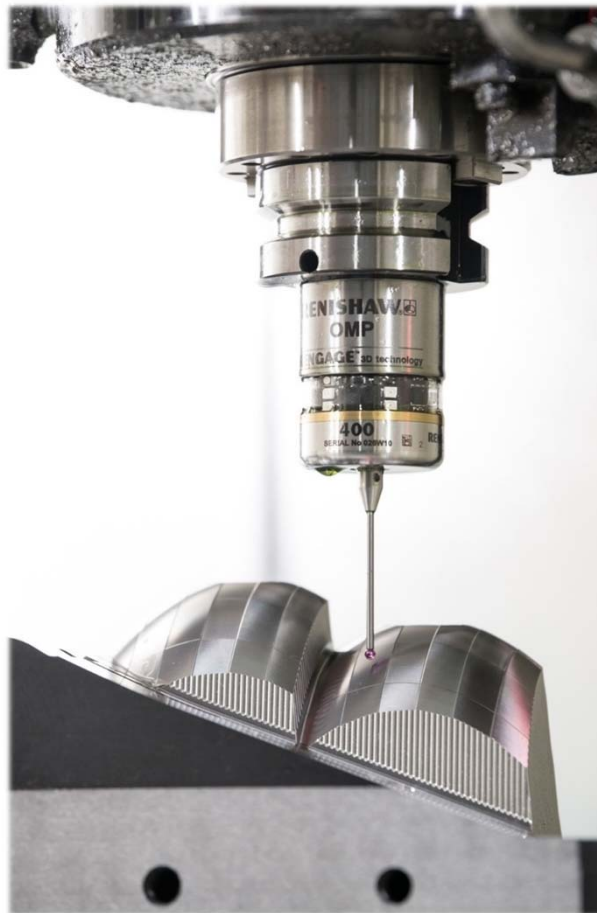

(三)立承智慧製造導入與分享

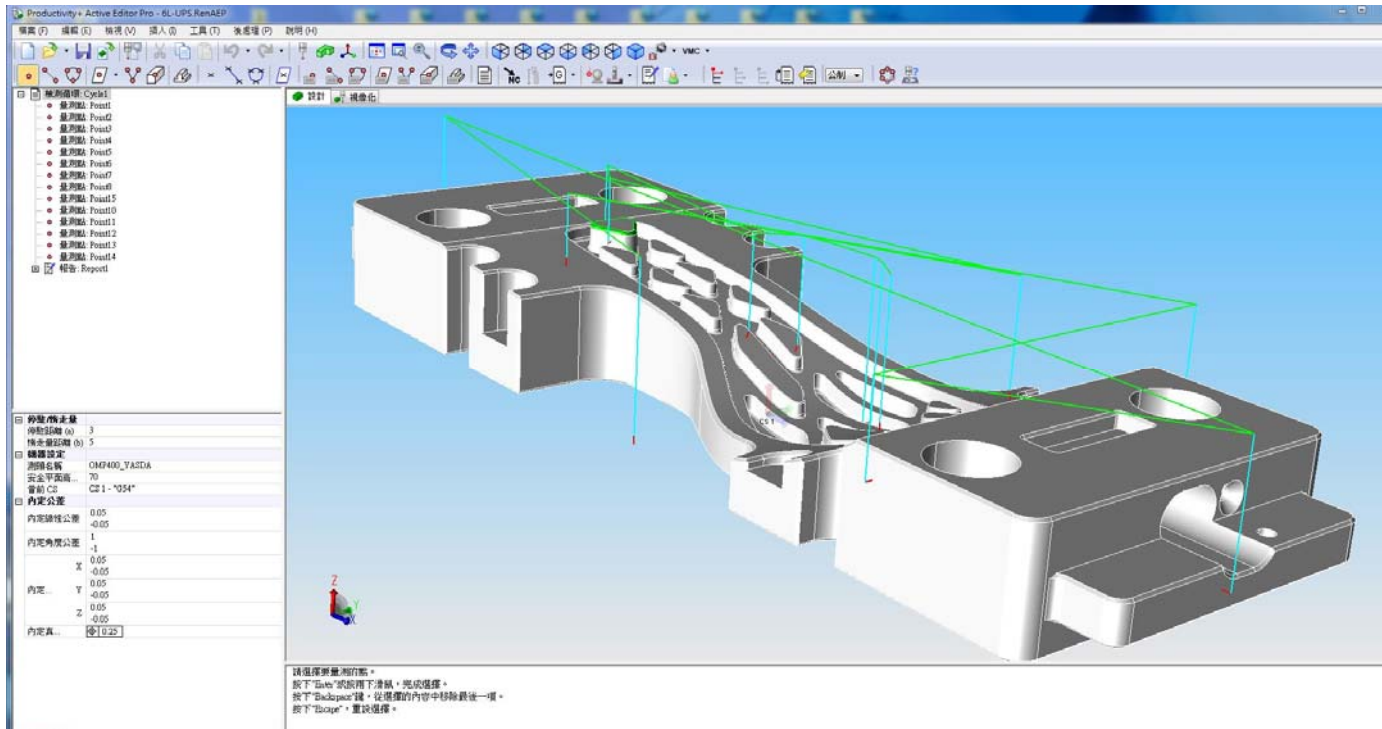

REPORT RPT
REPORT1
NOM ACT DEV LOWER UPPER INTOL

MEASURED POINT MPT
POINT1
POSITION X .0000 .0000 .0000
POSITION Y - 50.0000 - 49.9999 .0001
POSITION Z 29.0000 29.0000 .0000
MATERIALCONDITION - .0001

MEASURED POINT MPT
POINT2
POSITION X .0000 .0000 .0000
POSITION Y 50.0000 50.0023 .0023
POSITION Z 29.0000 29.0000 .0000
MATERIALCONDITION .0023

MEASURED POINT MPT
POINT3
POSITION X - 50.0000 - 49.9999 .0001
POSITION Y .0000 .0000 .0000
POSITION Z 29.0000 29.0000 .0000
MATERIALCONDITION - .0001

MEASURED POINT MPT
POINT4
POSITION X 50.0000 50.0009 .0009
POSITION Y .0000 .0000 .0000
POSITION Z 29.0000 29.0000 .0000
MATERIALCONDITION .0009

MEASURED POINT MPT
POINT5
POSITION X 4.6825 4.6836 .0011
POSITION Y - 24.9232 - 24.9228 .0004
POSITION Z 33.2988 33.2979 -.0009
MATERIALCONDITION - .0015

(三)立承智慧製造導入與分享

4.成果分享

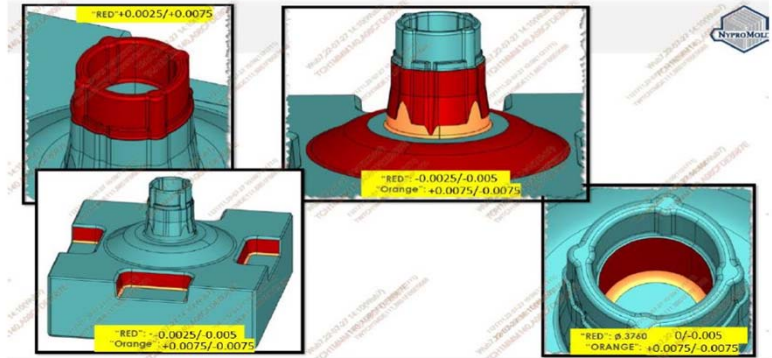
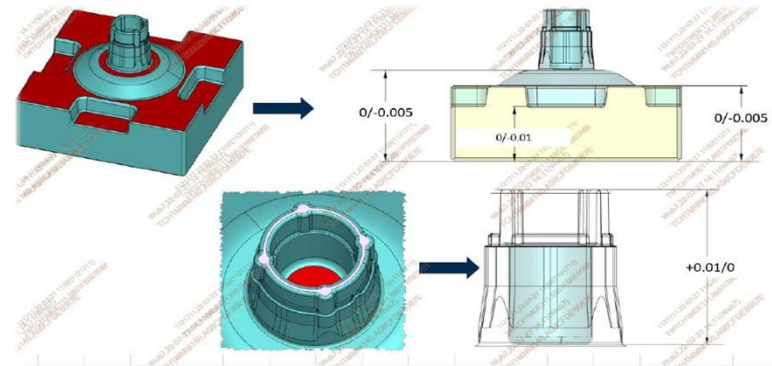

(三)立承智慧製造導入與分享

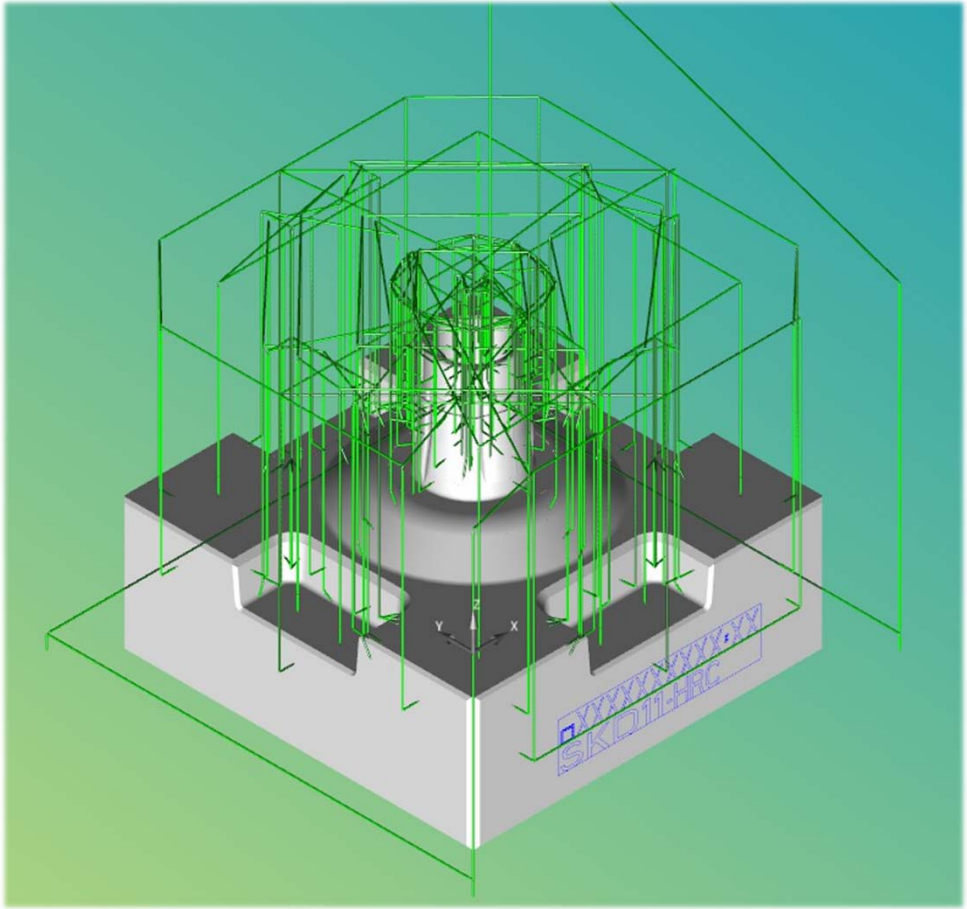

(三)立承智慧製造導入與分享

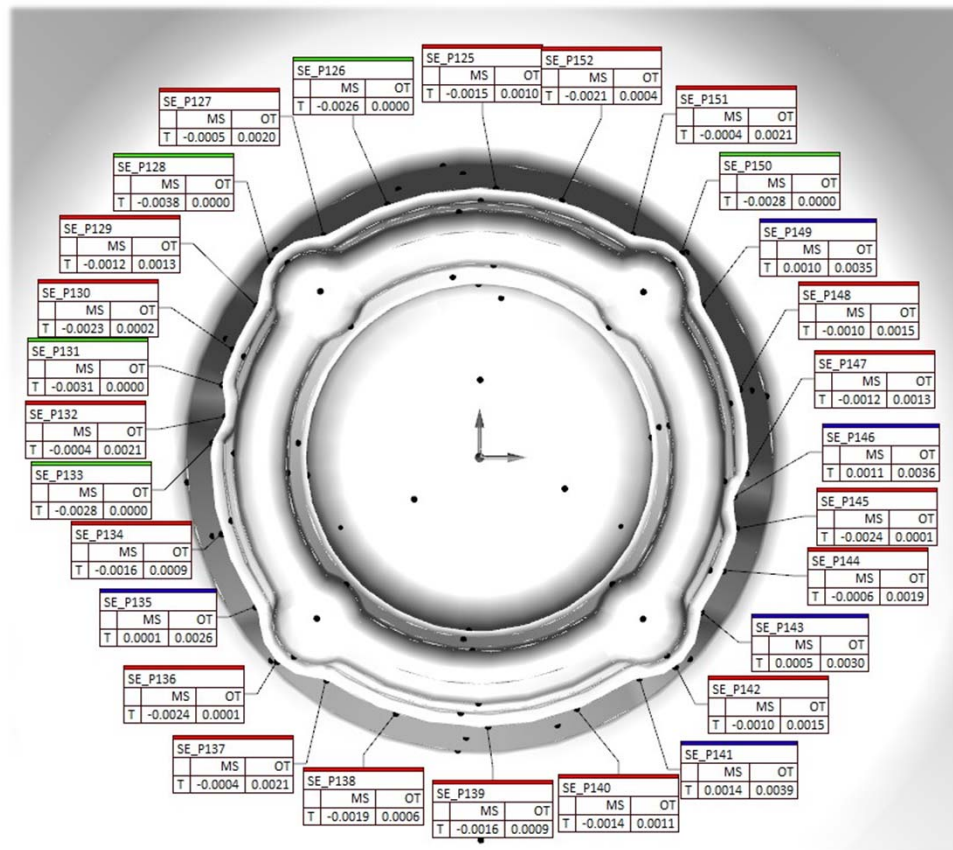

(三)立承智慧製造導入與分享

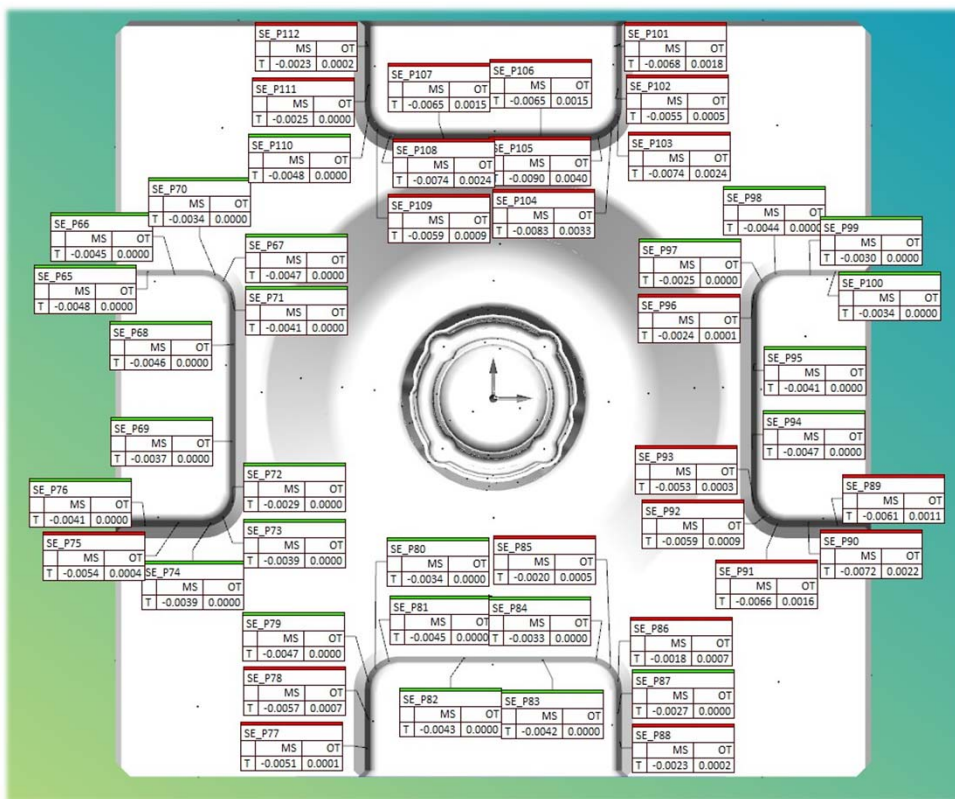

(三)立承智慧製造導入與分享

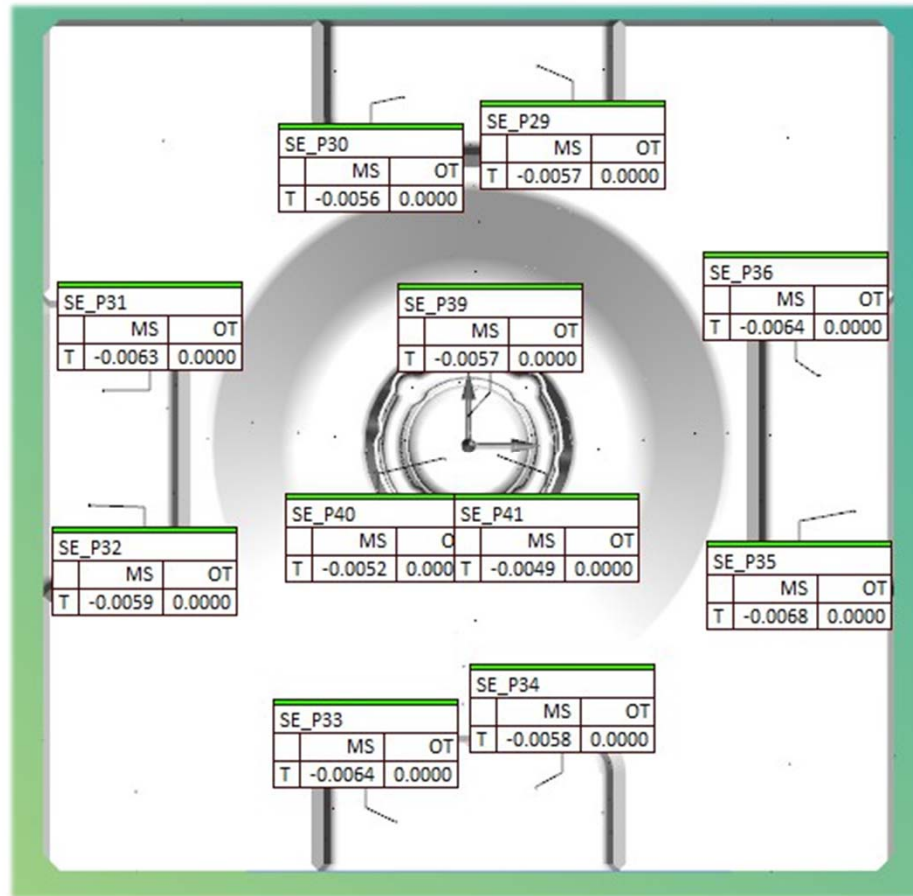

(三)立承智慧製造導入與分享

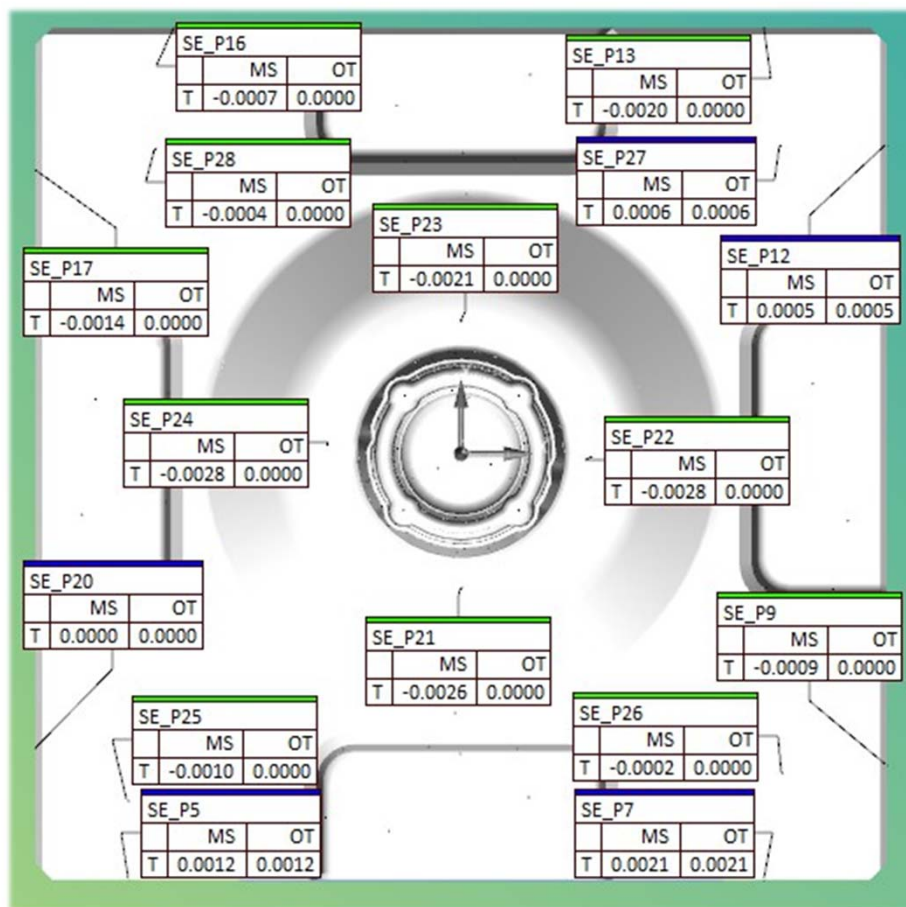

(三)立承智慧製造導入與分享

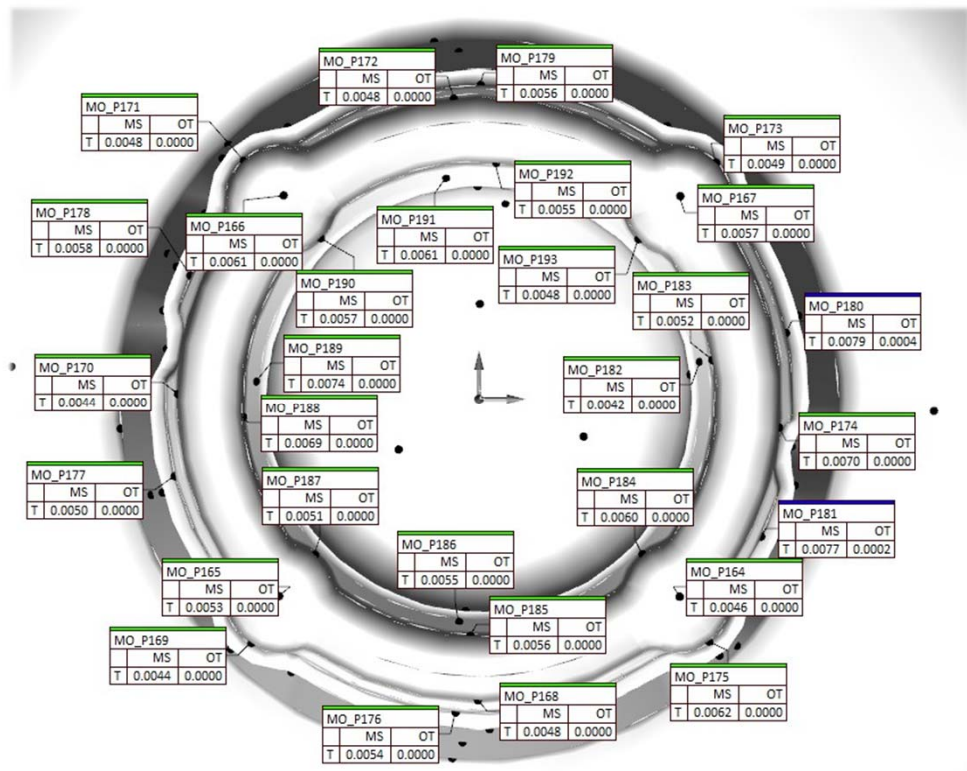



Look forward to creating
new opportunities with you



LIY CHENG
Liy cheng Precision Co., Ltd.



B
U
S
I
N
E
S
S